



Form SPT-IOM-1 600011

## SPTS/U SYSTEMS

### GAS-FIRED LOW-INTENSITY INFRARED TUBE HEATERS

# INSTALLATION, OPERATION, & MAINTENANCE INSTRUCTIONS

## SPTS

(STRAIGHT TUBE)

## SPTU

(U-TUBE)

### **! WARNING !**

Improper installation, adjustment, alteration, service or maintenance can cause property damage, injury or death. Read the installation, operating, and maintenance instructions thoroughly before installing or servicing this equipment.

#### **FOR YOUR SAFETY**

- If you smell gas: open windows; don't touch electrical switches, extinguish any open flames; evacuate the structure; call your gas supplier immediately.

#### **WARNING – NOT FOR RESIDENTIAL USE**

- Failure to comply with instructions could result in unsafe operation, property damage, personal injury, and/or death. A gas-fired appliance could expose you to substances in fuel or from fuel combustion, which have been determined by the State of California to cause cancer, birth defects or other reproductive harm. For industrial or commercial use only.
- Contact factory for further information. RETAIN these instructions for future reference.

## WARNINGS

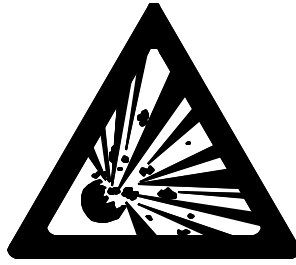
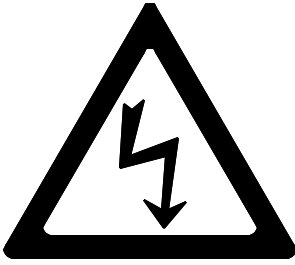

- Protect yourself and others by observing all safety information.

<b>WARNING</b>	<b>CAUTION</b>
<p style="text-align: center;"><b>FIRE OR EXPLOSION HAZARD</b></p> <p><i>Can cause property damage, severe injury or death.</i></p> <ul style="list-style-type: none"> <li>• Read manual carefully before installing, or servicing this equipment, or serious injury or death may result.</li> <li>• Check minimum clearance to combustibles to make certain that heater is in a safe location. Combustible items located too close to the heater could cause a <b>serious fire hazard</b>. In storage areas, signs for maximum permissible stacking height to maintain clearance from the heater to combustible materials must be posted adjacent to the heater thermostats or in the absence of such thermostats in a conspicuous location.</li> <li>• Operating the heater in an atmosphere containing combustible dust or flammable vapors is dangerous and may potentially result in injury or death.</li> <li>• Heaters must be oriented in such a way as to maintain minimum clearances to vehicles parked underneath them.</li> <li>• This heater expands and contracts with each cycle. The installation of the gas connection and mounting hardware must accommodate this movement; otherwise, a fire or explosion hazard may occur.</li> <li>• This heater is equipped with an automatic ignition and does not contain a pilot. <b>DO NOT</b> attempt to light the burner manually, this could result in serious personal injury or fire hazard.</li> </ul>	<p style="text-align: center;"><b>MECHANICAL HAZARD</b></p> <ul style="list-style-type: none"> <li>• <b>DO NOT</b> use high pressure to test the gas pipes with the burner still attached. This will cause damage to the controls within the burner requiring them to be replaced.</li> <li>• If heater is being operated in an atmosphere with a negative pressure or an atmosphere containing contaminants, an outside combustion air supply is required. Failure to provide outside combustion air may allow excessive heat to back up to the blower wheel and bearings severely shortening service life.</li> <li>• Correct inlet pressure is important to efficiency and long lasting operation of the burner.</li> <li>• The burner, tubing, and accessories expand and contract with each cycle. The system must be installed so that the mounting hardware and gas line will accommodate these changes.</li> <li>• All models of low-intensity heaters include a turbulator, which <b>must</b> be located in the <b>last</b> ten (10) feet (3.0 m) of the burner tube [exception: 15-foot (4.6 m) units have the turbulator in the <b>first</b> 10 feet (3.0 m).]</li> <li>• Before servicing the burner or removing the cover panel, all electrical and gas supplies must be disconnected.</li> <li>• Give consideration to construction such as partitions, storage racks, hoists, etc., and their relation to the installation of the heater.</li> <li>• The heater must be installed and serviced <b>ONLY</b> by trained gas installation and service personnel.</li> </ul>

## IMPORTANT

- Failure to follow these instructions may result in injury or property damage.
  - Low-intensity heaters **cannot** be used in the following environments: explosion-proof, or residential living/sleeping quarters.
  - Low-intensity heaters **may or may not** be used in the following environments: enclosed swimming pool, process heating, or contaminated atmosphere applications.
- NOTE: Contact factory if in any doubt.**

## TABLE OF CONTENTS

**This instruction manual may not cover all details or variations in this equipment, or cover every possible situation to be met in connection with installation, operation, or maintenance. Should problems arise that are not covered sufficiently in these instructions, the purchaser is advised to contact the engineering department for further information.**

<b>SECTION TITLES</b> – summary of information included	<b>PAGE(S)</b>
<b>WARNINGS</b> – precautions and important safety information	2
<b>TABLE OF CONTENTS</b>	3
<b>INSTALLATION CODES</b> – applicable codes and warnings; gas conversions	4
<b>CANADIAN ADDENDUM</b> – applicable codes and variances from this manual	5
<b>CLEARANCE TO COMBUSTIBLES</b> – minimum distances from heater to combustible objects	6
<b>MOUNTING CONSIDERATIONS</b> – minimum heater mounting heights, distances, angles and spacing; high altitude considerations	7
<b>OVERVIEW DRAWINGS</b> – overview of venting, suspension, location, and typical installation	8-9
<b>HEATER CONFIGURATIONS</b> – possible arrangements of heat exchangers; reflector options	10
<b>BASIC SYSTEM CONFIGURATIONS</b> – straight and U-tube configurations with component identification	11
<b>COMBUSTION CHAMBERS</b> – components and specifications of combustion chambers	12
<b>HEAT EXCHANGERS</b> – components and specifications of middle and exhaust end heat exchangers	13
<b>COMBUSTION AIR SUPPLY</b> – application, construction, dimensions, and illustrations	14
<b>EXHAUST VENTING</b> – application, construction, dimensions, and illustrations	15
<b>WINDY CONDITION NOTES</b> – methods for suspension and notes	16
<b>U-TUBE INSTALLATION</b> – suspension and orientation of U-tube heaters	17
<b>INSTALLATION</b> – preparation and installation	18-19
<b>ELECTRICAL SUPPLY AND THERMOSTATIC CONTROL</b> – electrical ratings, schematics, 24 and 120 VAC thermostat arrangements, illustrations	20-21
<b>GAS SUPPLY AND GAS PRESSURE</b> – gas piping, inlet and manifold pressures	22
<b>STARTUP</b> – procedures	23
<b>MAINTENANCE</b> – basic procedures	24
<b>TROUBLESHOOTING</b> – symptoms, possible causes and corrective actions	25
<b>REPLACEMENT PARTS</b> – exploded view and part descriptions	26

All rights reserved. No part of this work covered by the copyrights herein may be reproduced or copied by any means: graphic, electronic or mechanical, including photocopying, recording, taping, information storage and retrieval systems without written permission.

## INSTALLATION CODES

### ATTENTION

**Mount a copy of these instructions adjacent to heater and retain a copy for future reference.**

**A limited number of excerpts from various standards are outlined in the following instructions. However, the installer must be familiar with all of the various requirements and is responsible for compliance with the applicable codes.**

Gas-fired low-intensity infrared heaters are C.S.A. International Design Certified for either indoor or outdoor installation. If you have any questions call factory before attempting any installation work.

Gas-fired low-intensity infrared heaters are designed and manufactured in compliance with American National Standards Institute standard ANSI Z83.20-latest edition. Gas-fired low-intensity infrared heaters must be installed in accordance with applicable codes and only by a qualified agency. In the absence of local codes, installation must be in accordance with the National Fuel Gas Code ANSI Z223.1 / NFPA 54-latest edition. All electrical work must conform to the National Electrical Code ANSI / NFPA 70 - latest edition. The installation must meet the requirements of the Occupational Safety and Health Act (OSHA) which requires OSHA approved service and safety access to the systems after they are installed.

### GENERAL

All installations must be in accordance with ANSI Z223.1 / NFPA 54 - latest edition) National Fuel Gas Code especially:

SECTION 9.18 covers the general provisions for installing infrared heaters. Note the requirements for posting signs to specify the maximum permissible stacking height to maintain required clearances from heater to combustibles (9.18.2). Note also the exhaust requirement of 4 CFM/1000 BTUH (.38 m<sup>3</sup>/minute/kW) when operating in the unvented mode (9.18.3.1). (See Canadian Addendum section herein.)

Exhaust openings for removing the flue products shall be above the level of the heater (9.18.3.2).

SECTION 8.1.11.1 states that in commercial garages "Gas utilization equipment installed in enclosed, basement, or underground parking structures shall be installed in accordance with NFPA 88A, Standard for Parking Structures."

SECTION 8.2 Accessibility and Clearance.

SECTION 8.3 Air for Combustion and Ventilation.

### AIRCRAFT HANGARS

In aircraft hangars, the heaters must be installed in accordance with ANSI / NFPA 409-latest edition, chapter 5.

SECTION 5-4.5.2 specifies a clearance of ten (10) feet (3.05 m) to the bottom of the heater from the highest surface of the wings or engine enclosures of the highest aircraft which may be housed in the hangar.

SECTION 5-4.5.3 specifies a minimum clearance of eight (8) feet (2.44 m) from the floor to the heater in other sections of aircraft hangars such as offices or shops which may communicate with areas used for servicing and storage.

SECTION 5-4.5.4 specifies the heaters must be located so as to be protected from damage by aircraft or other objects such as cranes and moveable scaffolding. In addition, the heaters must be located so as to be accessible for servicing, adjustment, etc.

### PUBLIC GARAGES

In public garages, the heaters must be installed in accordance with National Fire Protection Association code NFPA 88B-latest edition, Section 3-2.3.

SECTION 3-2.3.1 states that overhead heaters may be used provided they are "located not less than eight (8) ft (2.4 m) above the floor and installed in accordance with the conditions of their approval." (**WARNING:** Minimum clearances indicated on the heater's serial plate must be maintained for vehicles parked below the heater.)

SECTION 3-2.3.2 states that "a distance shall be maintained between the heater and its vent and any adjacent combustible material (which is part of the building or its contents) in conformance with NFPA 54, National Fuel Gas Code".

### PARKING STRUCTURES

Approval requirements for parking structures are contained in NFPA 88A-latest edition and described in Section 4-2.

### MATERIAL SAFETY DATA SHEETS (MSDS)

Gas-fired low-intensity infrared heaters comply with the US Superfund Amendments and Reauthorization ACT (SARA) Title III. No Material Safety Data Sheets are required.

### UL LISTING

Gas-fired low-intensity infrared heaters are design certified by C.S.A. International for compliance with the current American National Standard Z83.20. C.S.A. International is the appropriate agency as they specialize in gas appliances while Underwriters Laboratories (UL) specialize in electric appliances.

If, however, UL were to design certify our heaters, it would be to the same American National Standard Z83.20. Certification by UL is not required, as it would be redundant.

### LOCAL APPROVALS

Gas-fired low-intensity infra-red heaters have been granted local approvals by such governing bodies as New York City (A Series: MEA 232-95-E Vol. 2; B and C Series MEA 417-86-E Vol. 5; MB Series MEA 233-95-E Vol. 2; MC Series 233-95-E Vol. 2); City of Minneapolis, Minnesota (#05444); the Commonwealth of Massachusetts; and the State of Nebraska.

### GAS/RATING CONVERSION OF INSTALLED HEATER

Conversions of gas type and BTUH ratings are possible. Consult factory for proper instructions. Identify the model and serial numbers from the serial plate located on the exterior of the burner housing. Note the radiant tube length. Review the systems listed in the BASIC SYSTEM CONFIGURATIONS section of these instructions to determine whether the installed heater can be converted as desired.

## CANADIAN ADDENDUM

### NOTES TO INSTALLER

Gas-fired low-intensity infrared heaters are C.S.A. International design certified for indoor installation only. They are designed and manufactured in compliance with *CSA Standard for Gas-Fired Low-Intensity Infrared Heaters*, CSA 2.34-2001.

The installation must conform with local building codes or, in the absence of local codes, with the current Canadian *Natural Gas and Propane Installation Code*, CSA B149.1.

The electrical connection shall comply with the local codes or, in the absence of local codes, with the current *Canadian Electrical Code*, CAN/CSA C22.1, Part I and Part II, and *Electrical Features of Fuel Burning Equipment*, CAN/CSA C22.2 No. 3.

### UNVENTED HEATERS

The exhaust venting requirement is 3 CFM per 1,000 BTUH (.29 m<sup>3</sup> per minute per kW) for natural gas and 4 CFM per 1,000 BTUH (.38 m<sup>3</sup> per minute per kW) for propane gas.

### AIRCRAFT HANGARS

Gas-fired low-intensity infrared heaters are suitable for use when installed in accordance with the current Canadian *Natural Gas and Propane Installation Code*, CSA B149.1.

### COMBUSTION AIR AND EXHAUST VENTING

Vent terminal clearances shall be in accordance with the current Canadian *Natural Gas and Propane Installation Code*, CSA B149.1.

A horizontal vent shall not terminate less than 6 feet (1.83 m) from a combustion air inlet or another appliance, 3 feet (.91 m) from any other building opening or any gas service regulator, or 7 feet (2.13 m) above grade and shall not terminate directly above a gas utility meter or gas service regulator.

### MANUAL SHUT-OFF VALVES

From the current Canadian *Natural Gas and Propane Installation Code*, CSA B149.1.

A manual shut-off valve shall be of the plug, ball, or eccentric type and it shall not be subjected to either a temperature or a pressure greater than its certified rating.

A readily accessible manual shut-off valve shall be installed to control the supply of gas to each appliance and the valve shall be located, in either the drop or riser, as close as possible to the valve train of a commercial and industrial type appliance.

## CLEARANCE TO COMBUSTIBLES\*

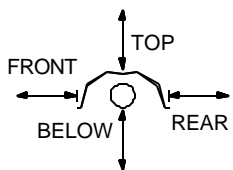
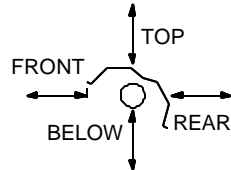
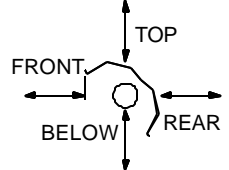
<p style="text-align: center;"><b>CLEARANCES APPLICABLE FOR ALL HEATERS*</b> Inches (Centimeters)</p> <p style="text-align: center;"><u>TOP OF REFLECTOR</u> 12 (31)</p> <p style="text-align: center;"><u>END OF BURNER</u> 12 (31)</p> <p style="text-align: center;"><u>END OF U-BEND</u> 68 (173)</p>	<p style="text-align: center;">Top, Front, and Rear clearances are measured from reflector. Below clearance is measured from bottom of tube. Clearance to combustibles* measurements are given in inches and (centimeters).</p> <div style="display: flex; justify-content: space-around; text-align: center;"> <div style="width: 30%;"> <p><u>0° MOUNTING</u></p>  </div> <div style="width: 30%;"> <p><u>1°-30° MOUNTING</u></p>  </div> <div style="width: 30%;"> <p><u>31°-45° MOUNTING</u></p>  </div> </div> <p style="text-align: center;">REFLECTOR WIDTH = 15.75" (40cm)</p>
---	---

SERIES	MBTUH (kW)	0° TO 30° REFLECTOR ANGLE			31° TO 45° REFLECTOR ANGLE		
		FRONT	REAR	BELOW	FRONT	REAR	BELOW
<b>A</b>	40 (12) 45 (13) 50 (15)	40 (102)	40 (102)	40 (102)	40 (102)	12 (31)	40 (102)
	55 (16) 60 (18)	50 (127)	50 (127)	50 (127)	50 (127)	12 (31)	50 (127)
<b>MB B</b>	65 (19) 70 (21) 75 (22) 80 (23) 85 (25)	24 (61)	24 (61)	60 (152)			
	90 (26) 95 (28) 100 (29)	24 (61)	24 (61)	60 (152)			
	105 (31) 110 (32) 115 (34) 120 (35)	32 (82)	32 (82)	72 (183)			
	<b>B / MC / C</b> 125 (37)						
	<b>MC / C</b> 130 (38)						
<b>C</b>	135 (40) 140 (41) 145 (42) 150 (44)	48 (122)	48 (122)	82 (209)	70 (189)	12 (31)	82 (209)
	155 (45) 160 (47) 165 (48) 170 (50) 175 (51)	58 (148)	58 (148)	92 (234)	80 (203)	12 (31)	92 (234)
	180 (53) 185 (54) 190 (56) 195 (57) 200 (59)	68 (173)	68 (173)	102 (259)	90 (229)	12 (31)	102 (259)

**\*MINIMUM CLEARANCES** specified in these tables must be maintained to combustible and other materials which may be damaged by temperatures 90°F above (50°C above) ambient room temperature. Minimum clearances to combustibles are also specified on each heater's serial plate. According to the National Fuel Gas Code (NFPA 54), "in locations used for the storage of combustible materials, signs must be posted to specify the maximum permissible stacking height to maintain required clearances from the heater to the combustibles." Gas supply lines, electrical supply lines, or sprinkler heads shall not be located within the minimum clearances to combustibles indicated above.

**NOTE:** Carefully examine surrounding materials near the heater. Materials, such as plastic, having low service temperature ratings can be discolored or damaged.

## MOUNTING CONSIDERATIONS

- **CLEARANCE TO COMBUSTIBLES MUST BE MAINTAINED.**
- Mounting heights lower than the recommended **Minimum Height** may be used if personnel are not kept directly under heater.
- The **Distance From Wall** measurement provides the most effective heat dispersion balance between the floors and walls.
- There is practically no limitation on a maximum mounting height.
- By design, a straight infra-red heater will produce more heat at the burner end than at the exhaust end. Locate the burner end where more heat is desired.

Reflector:	Standard				Parabolic				Standard & Parabolic
Mounting Angle:	Horizontal	30° - 45°	Horizontal	30° - 45°	Horizontal	30° - 45°	Horizontal	30° - 45°	Horizontal & 30° - 45°
Input MBTUH (kW)	Minimum Height ft (m)		Distance From Wall ft (m)		Minimum Height ft (m)		Distance From Wall ft (m)		Max. Distance Between Rows ft (m)
40 (12)	9.5 (2.9)	7.5 (2.3)	6 (1.8)	1 (0.3)	11.5 (3.5)	9.5 (2.9)	4 (1.2)	1 (0.3)	80 (24.4)
45-50 (13-15)	10.0 (3.0)	8.0 (2.4)	6 (1.8)	1 (0.3)	12.0 (3.7)	10.0 (3.0)	4 (1.2)	1 (0.3)	80 (24.4)
55-60 (16-18)	10.5 (3.2)	8.5 (2.6)	6 (1.8)	1 (0.3)	12.5 (3.8)	10.5 (3.2)	4 (1.2)	1 (0.3)	80 (24.4)
65-75 (19-22)	11.0 (3.4)	9.0 (2.7)	8 (2.4)	1 (0.3)	13.0 (4.0)	11.0 (3.4)	6 (1.8)	1 (0.3)	80 (24.4)
80-85 (23-25)	11.5 (3.5)	9.5 (2.9)	8 (2.4)	1 (0.3)	13.5 (4.1)	11.5 (3.5)	6 (1.8)	1 (0.3)	90 (27.4)
90-95 (26-28)	12.0 (3.7)	10.0 (3.0)	8 (2.4)	1 (0.3)	14.0 (4.3)	12.0 (3.7)	6 (1.8)	1 (0.3)	95 (29.0)
100-105 (29-31)	12.5 (3.8)	10.5 (3.2)	8 (2.4)	1 (0.3)	14.5 (4.4)	12.5 (3.8)	6 (1.8)	1 (0.3)	95 (29.0)
110-115 (32-34)	13.0 (4.1)	11.0 (3.4)	12 (3.7)	1 (0.3)	15.0 (4.6)	13.0 (4.1)	9 (2.7)	1 (0.3)	100 (30.5)
120 (35)	13.5 (4.1)	11.5 (3.5)	12 (3.7)	1 (0.3)	15.5 (4.7)	13.5 (4.1)	9 (2.7)	1 (0.3)	100 (30.5)
125 (37)	14.0 (4.3)	12.0 (3.7)	12 (3.7)	1 (0.3)	16.0 (4.9)	14.0 (4.3)	9 (2.7)	1 (0.3)	105 (32.0)
130 (38)	14.5 (4.4)	12.5 (3.8)	12 (3.7)	1 (0.3)	16.5 (5.0)	14.5 (4.4)	9 (2.7)	1 (0.3)	105 (32.0)
135-140 (40-41)	15.0 (4.6)	13.0 (4.0)	12 (3.7)	1 (0.3)	17.0 (5.2)	15.0 (4.6)	9 (2.7)	1 (0.3)	105 (32.0)
145 (42)	15.5 (4.7)	13.5 (4.1)	12 (3.7)	1 (0.3)	17.5 (5.3)	15.5 (4.7)	9 (2.7)	1 (0.3)	105 (32.0)
150 (44)	16.0 (4.9)	14.0 (4.3)	12 (3.7)	1 (0.3)	18.0 (5.5)	16.0 (4.9)	9 (2.7)	1 (0.3)	105 (32.0)
155-160 (45-47)	16.5 (5.0)	14.5 (4.4)	13 (4.0)	1 (0.3)	18.5 (5.6)	16.5 (5.0)	10 (3.0)	1 (0.3)	105 (32.0)
165-170 (48-50)	17.0 (5.2)	15.0 (4.6)	13 (4.0)	1 (0.3)	19.0 (5.8)	17.0 (5.2)	10 (3.0)	1 (0.3)	110 (33.5)
175-180 (51-53)	17.5 (5.3)	15.5 (4.7)	14 (4.3)	1 (0.3)	19.5 (5.9)	17.5 (5.3)	11 (3.4)	1 (0.3)	110 (33.5)
185-190 (54-56)	18.0 (5.5)	16.0 (4.9)	14 (4.3)	1 (0.3)	20.0 (6.1)	18.0 (5.5)	11 (3.4)	1 (0.3)	115 (35.1)
195-200 (57-59)	18.5 (5.6)	16.5 (5.0)	15 (4.6)	1 (0.3)	20.5 (6.2)	18.5 (5.6)	12 (3.7)	1 (0.3)	115 (35.1)

### HIGH ALTITUDE

If a heater is to be installed at a high altitude, in excess of two thousand feet (610 m) above sea level, consult the factory (U.S. & CANADA).

# OVERVIEW DRAWINGS (1 OF 2)

WHEN GAS PRESSURE EXCEEDS 14" (35 CM) W.C. A FIRST STAGE REGULATOR MUST BE INSTALLED.

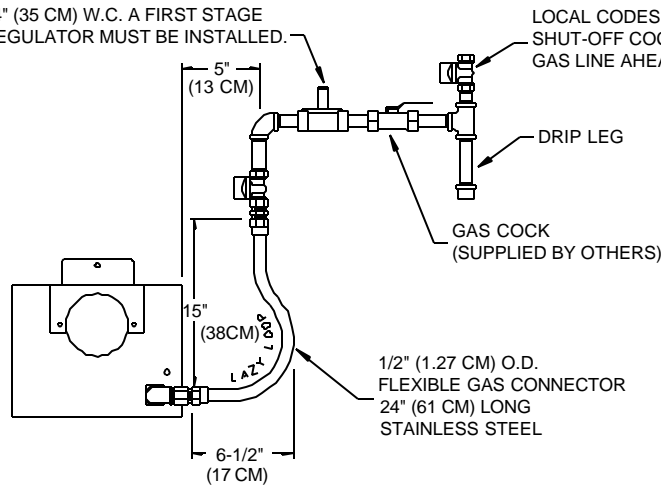

## GAS CONNECTION DIAGRAM

ALL HANGING CHAINS MUST BE PLUMB AND VERTICAL IN ALL DIRECTIONS WHEN INITIALLY INSTALLED

USE A SAFETY CHAIN WITH ENOUGH SLACK AS INDICATED. SAFETY CHAIN [MUST BE 1/0 TENS0 AND HAVE A MINIMUM WORKING LOAD RATING OF 200 LBS. (90.7 KG)] AND S-HOOK [1/4" (.64 CM) STEEL WIRE DIA., 3/4" (1.91 CM) INSIDE HOOK DIA., 350 LB. PULL TEST] TO BE PROVIDED BY OTHERS.

INLET AIR CAP MUST BE 6" (15 CM) HIGHER THAN SNOW DEPTH

ROOF FLASHING (NOT SUPPLIED)

DISTANCE FROM SUSPENSION POINT TO TOP OF COVER PLUS 6" (15 CM) = LENGTH OF SAFETY CHAIN

BURNER  
12" (30 CM) MIN. CLEARANCE

INLET AIR SLEEVE (SEAM TO BE AT TOP)

4" (10.2 CM) I.D. FLEX DUCT - 18" (46 CM) LONG WITH (2) TWO HOSE CLAMPS

SUPPLY PIPING MUST NOT EXCEED AN EQUIVALENT OF 35 LINEAR FEET (10.7 M) FOR 40 TO 125 MBTUH (11.7 - 36.6 KW) OR 40 LINEAR FEET (12.2 M) FOR 130 TO 200 MBTUH (38.1 KW - 58.6 KW). NO MORE THAN TWO 90° ELBOWS MAY BE USED. A 90° ELBOW IS EQUIVALENT TO 10 LINEAR FEET (3.0 M).

4" B-VENT ADAPTOR (PROVIDED BY OTHERS)

4" (10.2 CM) VENT PIPE ADAPTOR (STANDARD FACTORY ACCESSORY)

HANGER REQUIRED AT TUBE CLAMP TO SUPPORT BURNER (NOT TO SUPPORT REFLECTOR HERE)

4" (1.2m) MIN. 8" (2.4m) MAX.

COMBUSTION CHAMBER 4" (10.2 CM) O.D. X 10'-0" (3.048 M) LONG

ADDITIONAL COMBUSTION AIR SUPPLY (NOT SUPPLIED) SINGLE WALL 26 GAUGE (.044 CM) MINIMUM GALVANIZED SHEET METAL PIPE OR SCHEDULE 40 PVC (SEAM MUST BE AT TOP)

HEAT EXCHANGER 4" (10.2 CM) O.D. X 5'-0" (1.524 M) OR X 10'-0" (3.048 M) LONG

INLET AIR BOX (ALTERNATE OPTIONAL ACCESSORY) USE APPROPRIATE FASTENERS (NOT SUPPLIED)

INLET AIR CAP (OPTIONAL ACCESSORY)

"B" VENT PIPE ADAPTOR  
VENT CAP MUST BE 6" (15 CM) HIGHER THAN SNOW DEPTH  
ROOF FLASHING (NOT SUPPLIED)

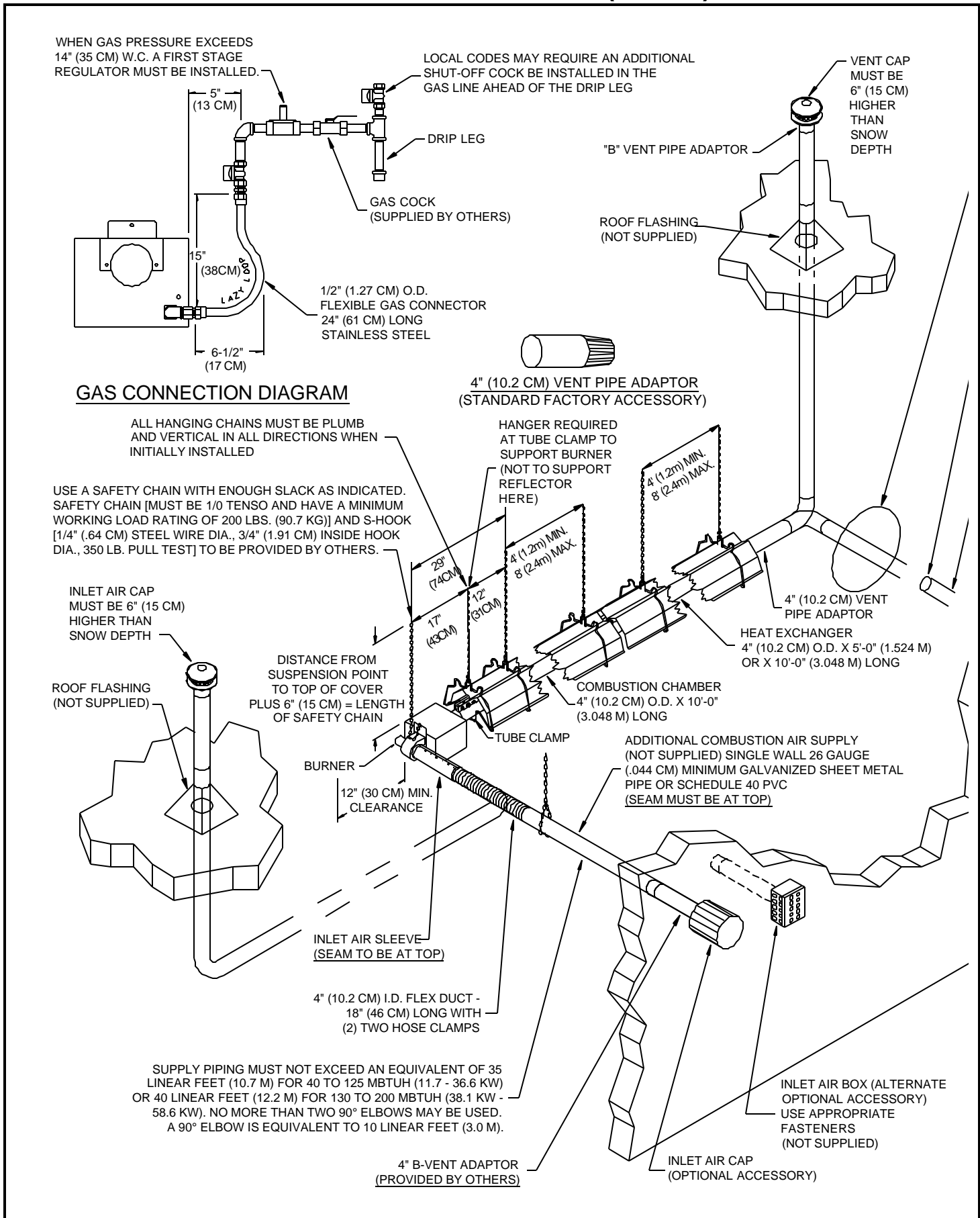

# OVERVIEW DRAWINGS (2 OF 2)

MAINTAIN 18 INCH (46 CM) MINIMUM CLEARANCE TO COMBUSTIBLES FOR ENTIRE LENGTH OF PIPING

FOR ALL INDOOR JOINTS, USE RTV SEALANT TO PREVENT HOT FLUE GAS LEAKAGE INTO THE BUILDING (USE A SHEET METAL PIPE AND CRIMPER FOR JOINING IDENTICAL SIZE SHEET METAL PIPES) USE THREE (3) #6 SHEET METAL SCREWS (SMS) PER VENT PIPE JOINT. THE VENT PIPE SEAM SHOULD BE ON TOP WITH ONE SMS ON TOP AND ONE SMS 120 DEGREES FROM THE TOP ON EACH SIDE.

ADDITIONAL EXHAUST VENT PIPING (NOT SUPPLIED) 4" (10.2 CM) I.D. SINGLE WALL 26 GAUGE (.044 CM) MINIMUM GALVANIZED SHEET METAL PIPE (SEAM TO BE AT TOP) (OR OTHER FACTORY-APPROVED MATERIALS) VENT PIPING MUST NOT EXCEED AN EQUIVALENT OF 35 LINEAR FEET (10.7 M) FOR 40 TO 125 MBTUH (11.7 - 36.6 KW) OR 40 LINEAR FEET (12.2 M) FOR 130 TO 200 MBTUH (38.1 - 58.6 KW). NO MORE THAN 2 ELBOWS MAY BE USED. A 90° ELBOW IS EQUIVALENT TO 10 LINEAR FEET (3.0 M). A 45° ELBOW IS EQUIVALENT TO 5 LINEAR FEET (1.5 M).

ADD NON-COMBUSTIBLE SUPPORT (NOT SUPPLIED) EVERY 5 OR 6 FEET (1.5 OR 1.8 M) APART AND ADEQUATE FOR THE PIPING WEIGHT

FOR COMBUSTIBLE WALLS ONLY USE A 2" (5.1 CM) CLEARANCE NON-COMBUSTIBLE VENTILATING METAL THIMBLE (NOT SUPPLIED).  
FOR NON-COMBUSTIBLE WALLS ONLY 4.250" (10.8 CM) DIA. HOLE FOR 4" (10.2 CM) O.D. PIPE ADD NON-COMBUSTIBLE PROTECTION AROUND THE HOLE IF NECESSARY.

(3) 90° BRACES EQUALLY SPACED USE APPROPRIATE FASTENERS (NOT SUPPLIED)

2'-0" (.610 M) MINIMUM CLEARANCE ABOVE OR BEYOND THE HIGHEST STRUCTURE OR SURFACE WITHIN 10'-0" (3.048 M) OF THE VENT

4" (10.2 CM) VENT CAP ASSEMBLY

WALL BRACE

USE APPROPRIATE FASTENER (NOT SUPPLIED) FOR ATTACHING TO BUILDING MATERIAL

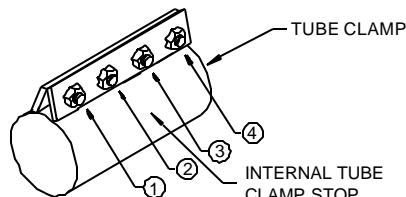

ALWAYS NEAREST THE BURNER

TIGHTEN NUTS A HALF TURN AT A TIME, IN A 2,3,4,1 SEQUENCE UNTIL THE FLANGES OF THE CLAMP TOUCH AND 65 FT-LBS (88 NM) IS ACHIEVED AT EACH NUT TO ASSURE PROPER SEATING OF THE CLAMPS INNER SLEEVE.

## TUBE CLAMP

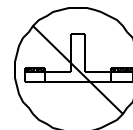

NEVER USE A STRAIGHT THROUGH TEE

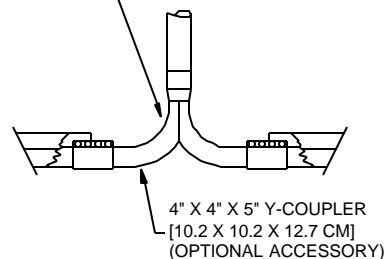

4" X 4" X 5" Y-COUPLER [10.2 X 10.2 X 12.7 CM] (OPTIONAL ACCESSORY)

## OPTIONAL COMMON VENTING THROUGH ROOF OR WALL

BOTH HEATERS MUST BE CONTROLLED BY A SINGLE THERMOSTAT

## CAUTION

- The first twenty (20) feet (6.1 m) of radiant tube extending from the burner MUST be installed straight.
- There is one exception. A U-Tube heater may have a 180 degree U-bend interposed AFTER the first ten (10) feet (3.0 m).
- Electrical wiring diagrams can be found in the ELECTRICAL SUPPLY AND THERMOSTATIC CONTROL section.

## HEATER CONFIGURATIONS

Low-intensity heaters can be arranged in many configurations; some common ones are illustrated below. It is important to limit the number of bends since each bend slows the movement of air inside the tube, resulting in decreased efficiency.

1. The **first twenty feet** (6.1 m) of radiant tube extending from the burner must be installed **straight** [**EXCEPTION:** a 15 foot (4.6 m) or 20 foot (6.1 m) heater may have a 180° U-bend interposed after the first 10 feet (3.0 m)].
2. Each system can use a maximum of **two (2)** 16 gauge (.17 cm) aluminized steel 45° elbows, **OR two (2)** 16 gauge (.17 cm) aluminized steel 90° elbows, **OR one (1)** 16 gauge (.17 cm) aluminized steel 180° U-bend. Elbows and U-bends can not be used **simultaneously** in the same system.
3. All tube sections of a unit must be mounted on the same horizontal plane. For exceptions or other configurations, consult factory.
4. Special reflectors are available: 90° elbow reflector, 180° U-bend reflector, side extension reflector and inverted V-deflectors. Contact factory for more information.
5. Use factory accessory elbows and U-bends only.

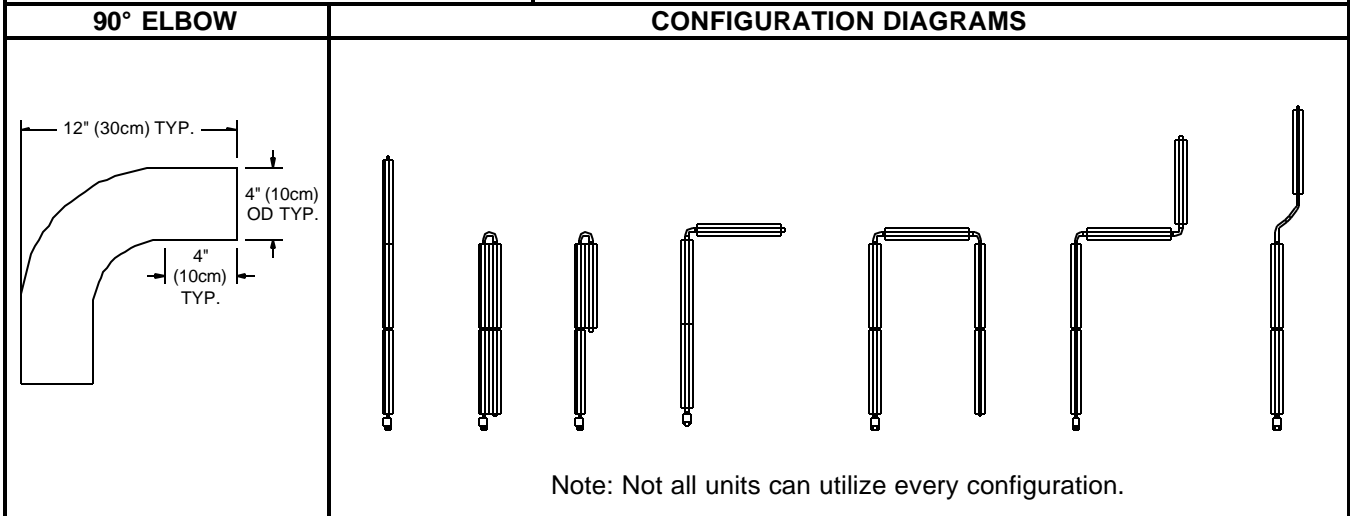
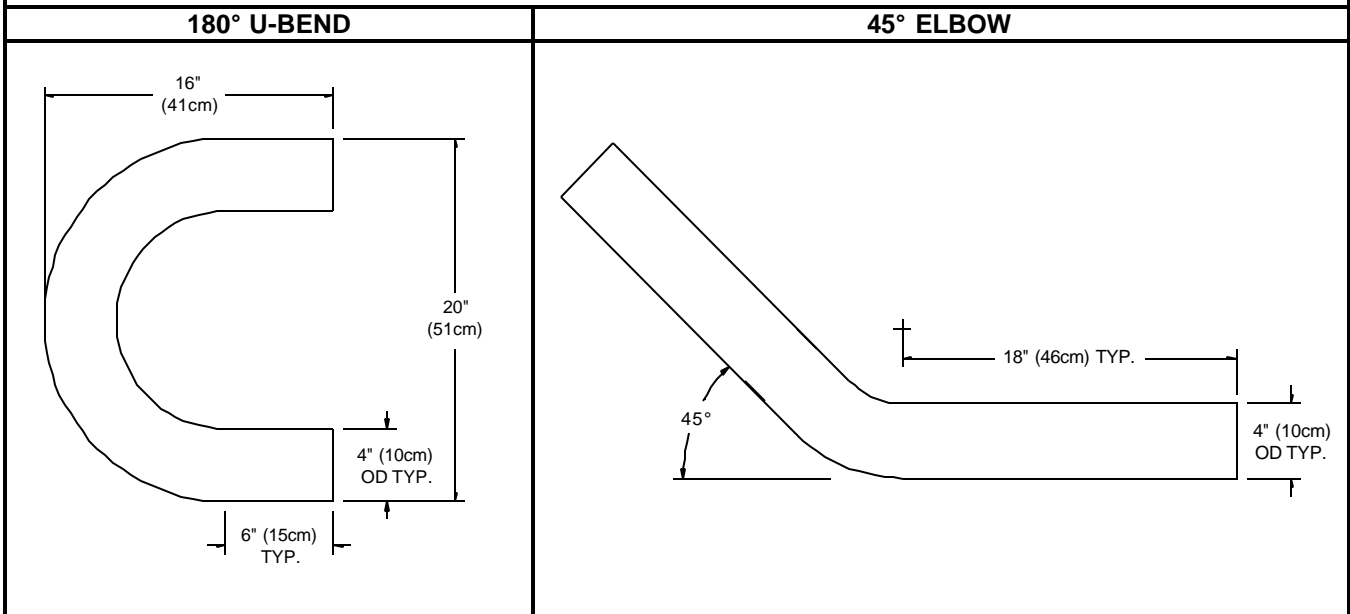

## BASIC SYSTEM CONFIGURATIONS

NOTE: These are the recommended configurations for your heater. Contact the factory with any questions.  
 LEGEND: L : LP/Propane gas, N : Natural gas, ▶ : Burner, U : 180° U-Bend.

<b>STRAIGHT TUBE</b>				<b>HEATER COMPONENTS</b>			
Burner Size MBTUH (kW)	Length Ft (m)	Series	Gas Type	▶	Combustion Chamber	Heat Exchangers	Exhaust End
40 (12)	10 (3.1)	A	N/L	▶	C9	----	----
40 (12)	15 (4.6)	A	N/L	▶	C9	----	H6
40 – 60 (12 – 18)	20 (6.1)	A	N/L	▶	C1	----	H1
65 – 85 (19 – 25)	20 (6.1)	MB	N(L)	▶	C2	----	H9(H1)
65 – 85 (19 – 25)	25 (7.6)	MB	N(L)	▶	C2	H6	H9(H1)
65 – 100 (19 – 29)	30 (9.1)	B	N(L)	▶	C2(C3)	H2	H5
105 – 130 (31 – 38)	30 (9.1)	MC	N - only	▶	C4	H2	H9
65 – 100 (19 – 29)	35 (10.6)	B	N(L)	▶	C2(C3)	H2 H6	H5
105 – 130 (31 – 38)	35 (10.6)	MC	N - only	▶	C4	H2 H6	H9
65 – 100 (19 – 29)	40 (12.2)	B	N(L)	▶	C2(C3)	H2 H2	H5
105 – 120 (31 – 35)	40 (12.2)	B	N/L	▶	C4	H2 H2	H5
125 (37)	40 (12.2)	B	N - only	▶	C4	H2 H2	H5
125 (37)	40 (12.2)	C	L - only	▶	C4	H2 H2	H5
130 – 150 (38 – 44)	40 (12.2)	C	N/L	▶	C4	H2 H2	H5
100 (29)	45 (13.7)	B	N(L)	▶	C2(C3)	H2 H2 H6	H5
105 – 120 (31 – 35)	45 (13.7)	B	N/L	▶	C4	H2 H2 H6	H5
125 (37)	45 (13.7)	B	N - only	▶	C4	H2 H2 H6	H5
125 (37)	45 (13.7)	C	L - only	▶	C4	H2 H2 H6	H5
130 – 150 (38 – 44)	45 (13.7)	C	N/L	▶	C4	H2 H2 H6	H5
100 (29)	50 (15.2)	B	N(L)	▶	C2(C3)	H2 H2 H2	H5
105 – 120 (31 – 35)	50 (15.2)	B	N/L	▶	C4	H2 H2 H6	H5
125 (37)	50 (15.2)	B	N - only	▶	C4	H2 H2 H6	H5
125 (37)	50 (15.2)	C	L - only	▶	C4	H2 H2 H2	H5
130 – 200 (38 – 59)	50 (15.2)	C	N/L	▶	C4	H2 H2 H2	H5
150 – 200 (44 – 59)	55 (16.8)	C	N/L	▶	C4	H2 H2 H2 H6	H5
150 – 200 (44 – 59)	60 (18.3)	C	N/L	▶	C4	H2 H2 H2 H2	H5
150 – 200 (44 – 59)	65 (19.9)	C	N/L	▶	C4	H2 H2 H2 H2 H6	H5
150 – 200 (44 – 59)	70 (21.3)	C	N/L	▶	C4	H2 H2 H2 H2 H2	H5
<b>U-TUBE</b>				<b>HEATER COMPONENTS</b>			
Burner Size MBTUH (kW)	Length Ft (m)	Series	Gas Type	▶	Combustion Chamber	Heat Exchangers	Exhaust End
40 (12)	15 (4.6)	A	N/L	▶	C9	U	H6
40 – 60 (12 – 18)	20 (6.1)	A	N/L	▶	C1	U	H1
65 – 85 (19 – 25)	20 (6.1)	MB	N(L)	▶	C2	U	H9(H1)
65 – 100 (19 – 29)	30 (9.1)	B	N(L)	▶	C2(C3)	H6 U H6	H5
105 – 130 (31 – 38)	30 (9.1)	MC	N - only	▶	C4	H6 U H6	H9
65 – 100 (19 – 29)	40 (12.2)	B	N(L)	▶	C2(C3)	H2 U H2	H5
105 – 120 (31 – 35)	40 (12.2)	B	N/L	▶	C4	H2 U H2	H5
125 (37)	40 (12.2)	B	N - only	▶	C4	H2 U H2	H5
125 (37)	40 (12.2)	C	L - only	▶	C4	H2 U H2	H5
130 – 150 (38 – 44)	40 (12.2)	C	N/L	▶	C4	H2 U H2	H5
100 (29)	50 (15.2)	B	N(L)	▶	C2(C3)	H2 H6 U H6 H2	H5
105 – 120 (31 – 35)	50 (15.2)	B	N/L	▶	C4	H2 H6 U H6 H2	H5
125 (37)	50 (15.2)	B	N - only	▶	C4	H2 H6 U H6 H2	H5
125 (37)	50 (15.2)	C	L - only	▶	C4	H2 H6 U H6 H2	H5
130 – 200 (38 – 59)	50 (15.2)	C	N/L	▶	C4	H2 H6 U H6 H2	H5
150 – 200 (44 – 59)	60 (18.3)	C	N/L	▶	C4	H2 H2 U H2 H2	H5
150 – 200 (44 – 59)	70 (21.3)	C	N/L	▶	C4	H2 H2 H6 U H6 H2 H2	H5

## COMBUSTION CHAMBERS

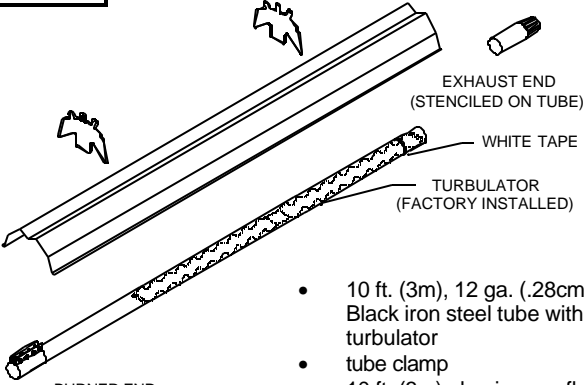
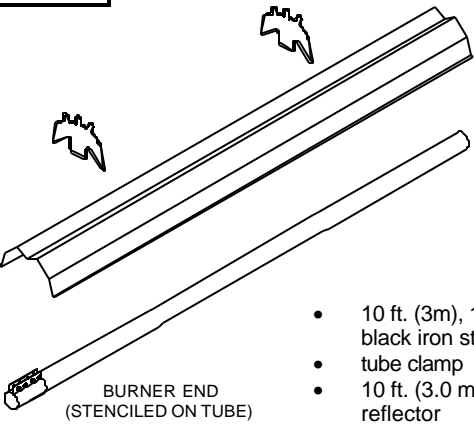
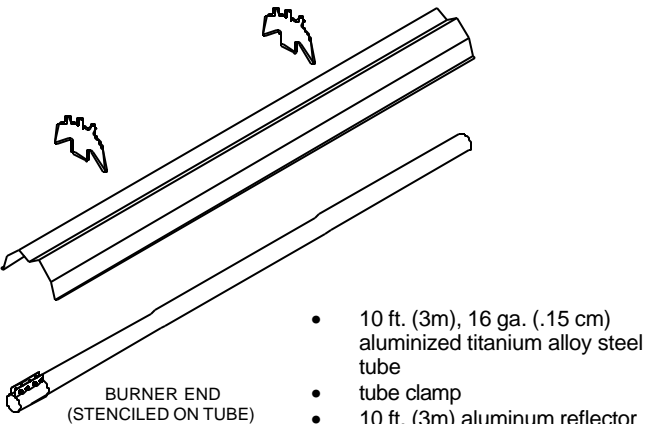
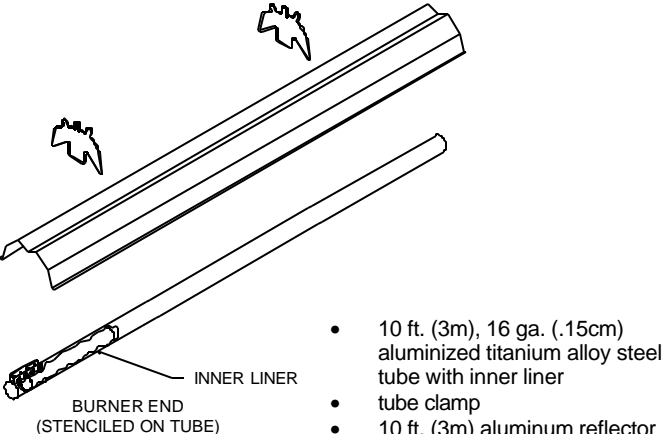
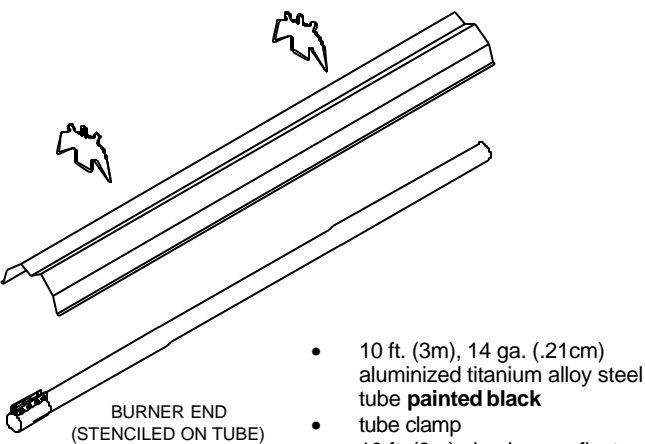
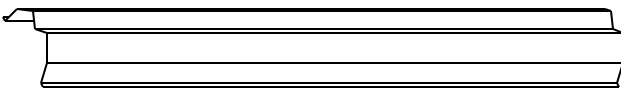
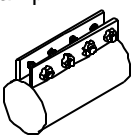
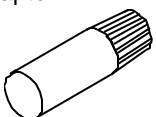
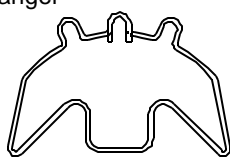
<p style="font-size: 24pt; font-weight: bold; margin: 0;">C9</p>	<p>40 MBTUH (10 and 15 ft. units only) [12 kW (3.0 and 4.6 m only)]</p>  <ul style="list-style-type: none"> <li>• 10 ft. (3m), 12 ga. (.28cm) Black iron steel tube with C9-turbulator</li> <li>• tube clamp</li> <li>• 10 ft. (3m) aluminum reflector</li> <li>• (2) tube/reflector hangers</li> <li>• vent pipe adaptor</li> </ul>
<p style="font-size: 24pt; font-weight: bold; margin: 0;">C1</p>	<p>40 thru 60 MBTUH (20 ft. unit only) [12-18 kW (6.1 m only)]</p>  <ul style="list-style-type: none"> <li>• 10 ft. (3m), 12 ga. (.28cm) black iron steel tube</li> <li>• tube clamp</li> <li>• 10 ft. (3.0 m) aluminum reflector</li> <li>• (2) tube/reflector hangers</li> </ul>
<p style="font-size: 24pt; font-weight: bold; margin: 0;">C2</p>	<p>65 thru 85 MBTUH (20 and 25 ft. MB units only) [19-25 kW (6.1 and 7.6 m MB only)] 65 thru 100 MBTUH (30 thru 50 ft. natural gas units) [19-29 kW (9.1-15.2 m natural gas)]</p>  <ul style="list-style-type: none"> <li>• 10 ft. (3m), 16 ga. (.15 cm) aluminized titanium alloy steel tube</li> <li>• tube clamp</li> <li>• 10 ft. (3m) aluminum reflector</li> <li>• (2) tube/reflector hangers</li> </ul>
<p style="font-size: 24pt; font-weight: bold; margin: 0;">C3</p>	<p>65 thru 100 MBTUH (30 thru 50 ft. propane gas units) [19-29 kW (9.1-15.2 m propane gas)]</p>  <ul style="list-style-type: none"> <li>• 10 ft. (3m), 16 ga. (.15cm) aluminized titanium alloy steel tube with inner liner</li> <li>• tube clamp</li> <li>• 10 ft. (3m) aluminum reflector</li> <li>• (2) tube/reflector hangers</li> </ul>
<p style="font-size: 24pt; font-weight: bold; margin: 0;">C4</p>	<p>105 thru 130 MBTUH (30 and 35 ft. MC units only) [31 - 38 kW (9.1 and 10.7 m MC only)] 105 - 200 MBTUH (40 thru 70 ft. units only) [31-59 kW (12.2-21.3 m only)]</p>  <ul style="list-style-type: none"> <li>• 10 ft. (3m), 14 ga. (.21cm) aluminized titanium alloy steel tube <b>painted black</b></li> <li>• tube clamp</li> <li>• 10 ft. (3m) aluminum reflector</li> <li>• (2) tube/reflector hangers</li> </ul>
<p>10 ft. (3m) reflector [length approx. 119" (302cm)]</p>  <div style="display: flex; justify-content: space-around; align-items: flex-start; margin-top: 10px;"> <div style="text-align: center;"> <p>Tube clamp</p>  </div> <div style="text-align: center;"> <p>Vent pipe adaptor</p>  </div> </div> <div style="text-align: center; margin-top: 10px;"> <p>Tube/reflector hanger</p>  </div>	

# HEAT EXCHANGERS

## MIDDLE HEAT EXCHANGER COMPONENTS

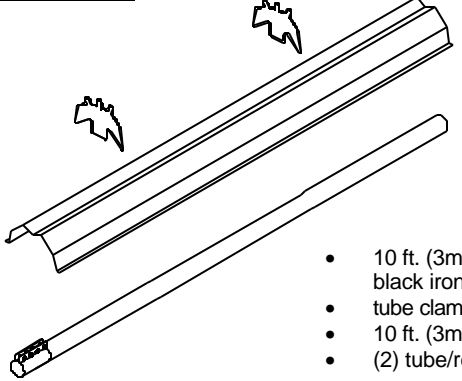
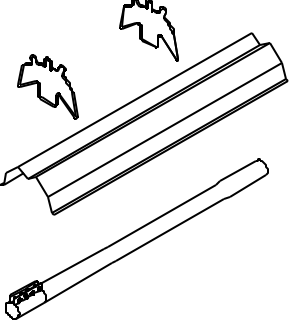
<h3>H2</h3>	<p>65 thru 200 MBTUH (30 thru 70 ft units) [19-59 kW (9.1-21.3 m)]</p>	<h3>H6</h3>	<p>40 MBTUH [ONLY 15 ft end tube] [12 kW (ONLY 4.6 m end tube)] 65 thru 200 MBTUH (25 thru 70 ft units) [19-59 kW (7.6-21.3 m)]</p>
 <ul style="list-style-type: none"> <li>• 10 ft. (3m), 12 ga. (.28cm) black iron steel tube</li> <li>• tube clamp</li> <li>• 10 ft. (3m) aluminum reflector</li> <li>• (2) tube/reflector hangers</li> </ul>		 <ul style="list-style-type: none"> <li>• 5 ft. (1.5m), 12 ga. (.28cm) black iron steel tube</li> <li>• tube clamp</li> <li>• 5 ft. (1.5m) aluminum reflector</li> <li>• (2) tube/reflector hangers</li> </ul>	

## EXHAUST END HEAT EXCHANGER COMPONENTS

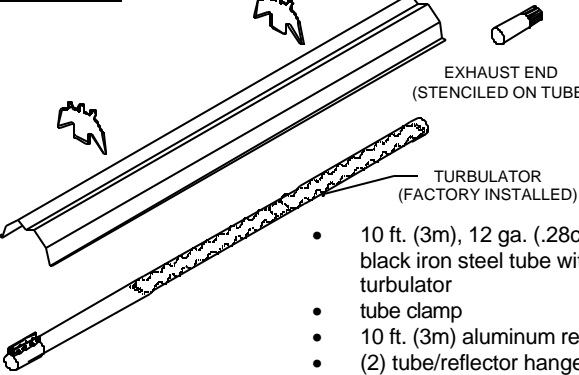
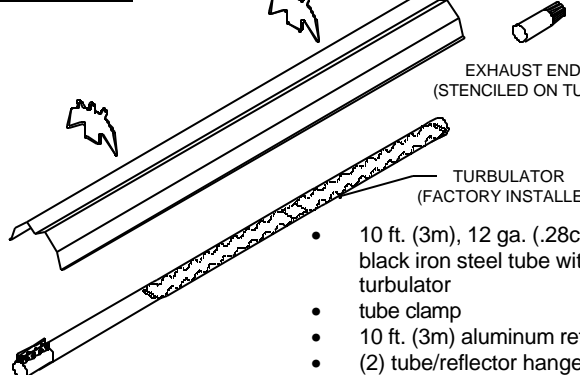
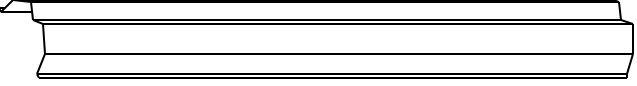
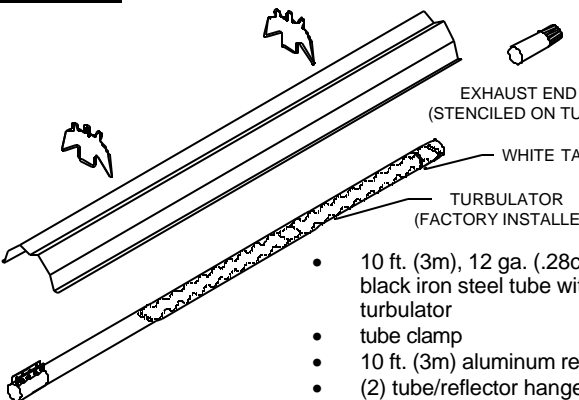
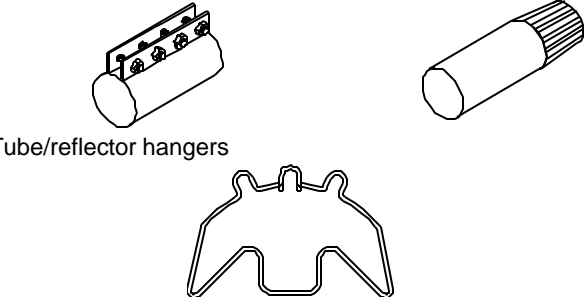
<h3>H1</h3>	<p>40 thru 60 MBTUH (20 ft unit) [12-18 kW (6.1 m)], 65 thru 85 MBTUH (20 and 25 ft propane gas MB units) [19 -25 kW (6.1 and 7.6 m natural gas MB units)]</p>	<h3>H5</h3>	<p>65 thru 200 MBTUH (excluding 20 and 25 ft MB units, and 30 and 35 ft MC units) [19-59 kW (excluding 6.1 and 7.6 m MB, and 9.1 and 10.7 m)]</p>
 <p>EXHAUST END (STENCILED ON TUBE)</p> <p>TURBULATOR (FACTORY INSTALLED)</p> <ul style="list-style-type: none"> <li>• 10 ft. (3m), 12 ga. (.28cm) black iron steel tube with H1-turbulator</li> <li>• tube clamp</li> <li>• 10 ft. (3m) aluminum reflector</li> <li>• (2) tube/reflector hangers</li> <li>• vent pipe adaptor</li> </ul>		 <p>EXHAUST END (STENCILED ON TUBE)</p> <p>TURBULATOR (FACTORY INSTALLED)</p> <ul style="list-style-type: none"> <li>• 10 ft. (3m), 12 ga. (.28cm) black iron steel tube with H5-turbulator</li> <li>• tube clamp</li> <li>• 10 ft. (3m) aluminum reflector</li> <li>• (2) tube/reflector hangers</li> <li>• vent pipe adaptor</li> </ul>	
<h3>H9</h3>	<p>65 thru 85 MBTUH (20 and 25 ft natural gas MB units) [19 -25 kW (6.1 and 7.6 m natural gas MB units)], 105 thru 130 MBTUH (30 and 35 ft natural gas MC units) [31-38 kW (9.1-10.7 m natural gas MC)]</p>	<p>10 ft. (3m) reflector [length approx. 119" (302cm)]</p> 	
 <p>EXHAUST END (STENCILED ON TUBE)</p> <p>WHITE TAPE</p> <p>TURBULATOR (FACTORY INSTALLED)</p> <ul style="list-style-type: none"> <li>• 10 ft. (3m), 12 ga. (.28cm) black iron steel tube with H9-turbulator</li> <li>• tube clamp</li> <li>• 10 ft. (3m) aluminum reflector</li> <li>• (2) tube/reflector hangers</li> <li>• vent pipe adaptor</li> </ul>		<p>Tube clamp</p> <p>Vent pipe adaptor</p> <p>Tube/reflector hangers</p> 	

# COMBUSTION AIR SUPPLY

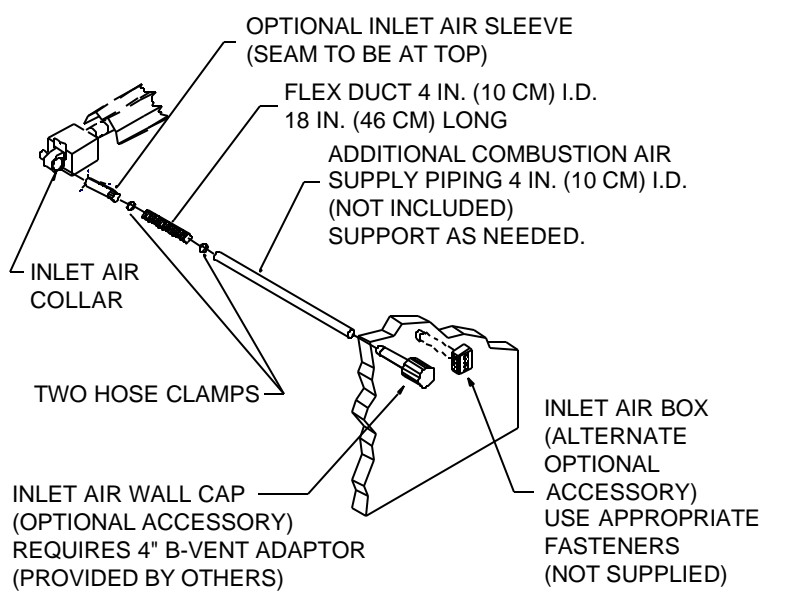
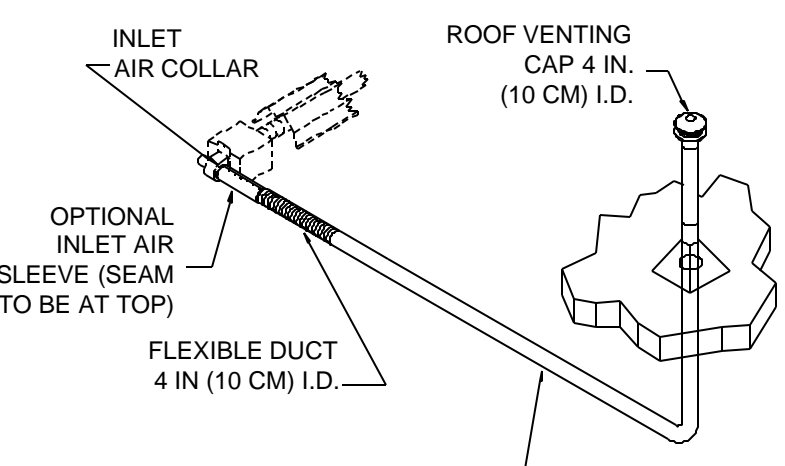
GENERAL NOTES	MAXIMUM LENGTHS OF AIR SUPPLY PIPE				
<ul style="list-style-type: none"> <li>Atmospheric air for combustion may come from either outdoors or indoors (from within the building).</li> <li>Installation of combustion air supply must comply with the instructions, drawings, and installation notes provided in this section.</li> </ul>	<table style="width: 100%; border-collapse: collapse;"> <tr> <td style="width: 50%; text-align: center;">40 TO 125 MBTUH (12 – 37 kW)</td> <td style="width: 50%; text-align: center;"><b>35</b> linear ft. (10.7 m)*</td> </tr> <tr> <td style="text-align: center;">130 TO 200 MBTUH (38 – 59 kW)</td> <td style="text-align: center;"><b>40</b> linear ft. (12.2 m)*</td> </tr> </table> <p style="text-align: center;">*Each 90 degree elbow inserted in the venting system is equivalent to 10 linear ft. (3.0 m). *Each 45 degree elbow inserted in the venting system is equivalent to 5 linear ft. (1.5 m).</p> <p style="text-align: center;">A maximum of <b>two</b> 90 degree elbows or their equivalent are allowed (e.g. one 90 degree elbow plus two 45 degree elbows; or four 45 degree elbows, etc.)</p>	40 TO 125 MBTUH (12 – 37 kW)	<b>35</b> linear ft. (10.7 m)*	130 TO 200 MBTUH (38 – 59 kW)	<b>40</b> linear ft. (12.2 m)*
40 TO 125 MBTUH (12 – 37 kW)	<b>35</b> linear ft. (10.7 m)*				
130 TO 200 MBTUH (38 – 59 kW)	<b>40</b> linear ft. (12.2 m)*				
OUTDOOR AIR SUPPLY	THRU-THE-WALL (OUTDOORS)				
<ul style="list-style-type: none"> <li>Atmospheric air for combustion may come from either outdoors or indoors (from within the building).</li> <li>Installation of combustion air supply must comply with the instructions, drawings, and installation notes provided in this section.</li> <li>In buildings contaminated with excessive dust or dirt, or containing substances which when combined with flame and exhaust products result in corrosive gasses or those under a negative pressure, or high humidity areas, combustion air must come from outdoors.</li> <li>Outdoor air supply may be accomplished by bringing in air through piping from either the roof or wall as the drawings illustrate.</li> <li>When combustion air is supplied from outdoors, the heater must also be vented to the outdoors (<b>EXCEPT</b> high humidity environments consult factory).</li> <li>The roof venting cap used for inlet air cap (roof), inlet air wall cap or inlet air box (wall) must be located at least three (3) feet (.91 m) away from any vent termination and in a manner to prevent blockage by snow.</li> <li>Components supplied by others must be identical to those specified in this manual and be Metalbestos brand, or equal. <b>NO SUBSTITUTIONS.</b></li> <li>Single wall 4" (10.2 cm) I.D., 26-gauge (.044 cm) minimum stainless or galvanized sheet metal pipe or schedule 40 PVC is recommended for combustion air supply piping.</li> <li>It may be desirable to insulate piping with 1 inch (2.54 cm) of pipe insulation to eliminate condensation from warm inside air.</li> <li>DO NOT use collapsible material for combustion air supply, as it will restrict the proper amount of combustion air from being supplied to the burner.</li> <li>An optional blower enclosure extends the burner housing to enclose the blower. The outdoor air piping is then attached to the enclosure, isolating the outside of the blower and motor from contaminants.</li> </ul>	 <p style="text-align: center;"><b>THRU-THE-WALL (OUTDOORS)</b></p> <p style="text-align: center;">OPTIONAL INLET AIR SLEEVE (SEAM TO BE AT TOP)</p> <p style="text-align: center;">FLEX DUCT 4 IN. (10 CM) I.D. 18 IN. (46 CM) LONG</p> <p style="text-align: center;">ADDITIONAL COMBUSTION AIR SUPPLY PIPING 4 IN. (10 CM) I.D. (NOT INCLUDED) SUPPORT AS NEEDED.</p> <p style="text-align: center;">INLET AIR COLLAR</p> <p style="text-align: center;">TWO HOSE CLAMPS</p> <p style="text-align: center;">INLET AIR WALL CAP (OPTIONAL ACCESSORY) REQUIRES 4" B-VENT ADAPTOR (PROVIDED BY OTHERS)</p> <p style="text-align: center;">INLET AIR BOX (ALTERNATE OPTIONAL ACCESSORY) USE APPROPRIATE FASTENERS (NOT SUPPLIED)</p>				
INDOOR AIR SUPPLY	THRU-THE-ROOF (OUTDOORS)				
<ul style="list-style-type: none"> <li>When combustion air is to be taken from inside a tightly closed building, an opening must be installed to supply the burner with sufficient air for combustion.</li> <li>For every 4,000 BTUH (1.17 kW) input of the total input of <b>ALL</b> gas-fired equipment, one (1) square inch (6.45 cm<sup>2</sup>) or more of free area opening must be provided.</li> <li>The openings should be located above the heaters to reduce the effect of drafts.</li> <li>Do not draw combustion air into the heater from attic space. There is no guarantee adequate air will be supplied</li> </ul>	<p style="text-align: center;">ROOF VENTING CAP USED FOR INLET AIR MUST BE 6 IN. (15 CM) HIGHER THAN SNOW DEPTH.</p>  <p style="text-align: center;"><b>THRU-THE-ROOF (OUTDOORS)</b></p> <p style="text-align: center;">INLET AIR COLLAR</p> <p style="text-align: center;">OPTIONAL INLET AIR SLEEVE (SEAM TO BE AT TOP)</p> <p style="text-align: center;">FLEXIBLE DUCT 4 IN (10 CM) I.D.</p> <p style="text-align: center;">ROOF VENTING CAP 4 IN. (10 CM) I.D.</p> <p style="text-align: center;">ADDITIONAL COMBUSTION AIR SUPPLY PIPING 4 IN. (10 CM) I.D. (NOT INCLUDED) SUPPORT AS NEEDED.</p>				

# EXHAUST VENTING

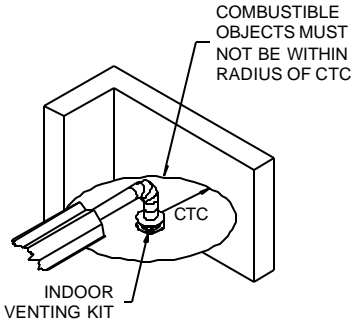
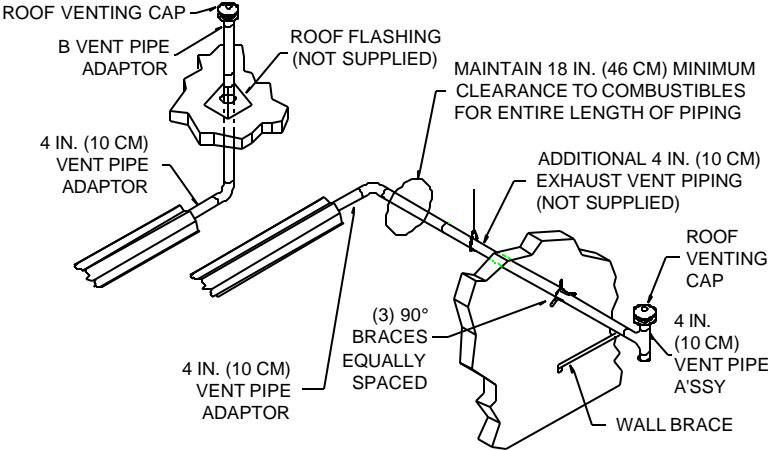
INDIRECT INDOOR VENTING	INSIDE OF BUILDING																														
<ul style="list-style-type: none"> <li>A heater that is vented indoors is classified as Category I by the National Fuel Gas Code.</li> <li>At least 4 CFM of exhaust per 1,000 BTUH (.38 m<sup>3</sup> per minute per kW) must be provided. Supply and exhaust air must be provided by natural or mechanical means. For Canada see CANADIAN ADDENDUM section.</li> <li>For supply and exhaust air by natural means, fresh air/ exhaust openings are required.</li> <li>Fresh air openings should be below the indoor venting kit.</li> <li>Exhaust openings must be located above the heaters.</li> <li>For supply and exhaust air by mechanical means, provision must be made so the flow of gas to the heater is allowed only when the mechanical exhaust is in operation.</li> <li>Combustion air must not be provided directly from outdoors to the inlet air collar on the burner. (For exceptions see COMBUSTION AIR SUPPLY).</li> </ul>	<p><b>CLEARANCE TO COMBUSTIBLES (CTC) MUST BE MAINTAINED FROM EXHAUST END OF HEATER.</b></p> <table border="1" data-bbox="748 331 1104 531"> <thead> <tr> <th>RATING MBTUH (kW)</th> <th>CTC*</th> </tr> </thead> <tbody> <tr> <td>40 to 60 (12 - 18)</td> <td>10" (25 cm)</td> </tr> <tr> <td>65 to 100 (19 - 29)</td> <td>30" (76 cm)</td> </tr> <tr> <td>105 to 125 (31 - 37)</td> <td>38" (97 cm)</td> </tr> <tr> <td>130 to 150 (38 - 44)</td> <td>48" (122 cm)</td> </tr> <tr> <td>155 to 175 (45 - 51)</td> <td>58" (147 cm)</td> </tr> <tr> <td>180 to 200 (53 - 59)</td> <td>68" (173 cm)</td> </tr> </tbody> </table> <p>*CTC is measured from the end of the Indoor Venting Kit.</p>  <p>Minimum clearance from ceiling: 15" (38 cm) is measured from top of reflector.</p>			RATING MBTUH (kW)	CTC*	40 to 60 (12 - 18)	10" (25 cm)	65 to 100 (19 - 29)	30" (76 cm)	105 to 125 (31 - 37)	38" (97 cm)	130 to 150 (38 - 44)	48" (122 cm)	155 to 175 (45 - 51)	58" (147 cm)	180 to 200 (53 - 59)	68" (173 cm)														
RATING MBTUH (kW)	CTC*																														
40 to 60 (12 - 18)	10" (25 cm)																														
65 to 100 (19 - 29)	30" (76 cm)																														
105 to 125 (31 - 37)	38" (97 cm)																														
130 to 150 (38 - 44)	48" (122 cm)																														
155 to 175 (45 - 51)	58" (147 cm)																														
180 to 200 (53 - 59)	68" (173 cm)																														
<p><b>DIRECT OUTDOOR VENTING</b></p>	<p><b>THROUGH THE WALL AND ROOF</b></p>																														
<ul style="list-style-type: none"> <li>A heater vented directly outdoors is classified as Category III by the National Fuel Gas Code.</li> <li>It may be vented through either the roof or wall singularly or in conjunction with no more than one other heater with a single thermostat. To commonly vent more than two heaters consult the factory.</li> <li>Use 4 in. (10.2 cm) I.D. single wall stainless or galvanized sheet metal pipe of not less than 26 gauge (.044 cm) (or other factory approved materials). Place seam at the top.</li> <li>Use RTV silicone adhesive sealant liberally at all vent pipe joints.</li> <li>Use three (3) #6 sheet metal screws per vent pipe joint – 120° apart starting at the top.</li> <li>1 inch (2.5 cm) thick pipe insulation wrapped around the single wall sheet metal pipe is recommended.</li> <li>By code, the use of dual wall pipe for outdoor venting is limited to appliances with neutral or negative pressures. Local authorities may waive this provision since the heaters are approved for indoor venting with proper exhaust and leakage due to condensation being greatly reduced.</li> <li>Be certain to get approval for either type of vent piping from local authorities.</li> <li>Vent pipes must be well supported due to the extra stress that occurs during expansion of the unit when operating.</li> <li>Vent caps must be identical, or equal, to those specified in this manual which are of the Metalbestos brand. This is critical to the heater's operation and to maintain C.S.A. certification.</li> <li>Heater must not be vented in between buildings less than 10 feet (3.0 m) apart or above public walkways, doors or windows.</li> </ul>	<p>ROOF VENTING CAP MUST BE 6 IN. (15 CM) HIGHER THAN SNOW DEPTH.</p> 																														
<p><b>IMPORTANT</b></p>	<p><b>DISTANCES OF EXHAUST VENT FROM:</b></p> <table border="1" data-bbox="737 1318 1541 1690"> <thead> <tr> <th></th> <th>BELOW Inches (cm)</th> <th>HORIZONTAL Inches (cm)</th> <th>ABOVE Inches (cm)</th> </tr> </thead> <tbody> <tr> <td>Door</td> <td>N/A</td> <td>48 (122)</td> <td>N/A</td> </tr> <tr> <td>Window</td> <td>48 (122)</td> <td>12 (30)</td> <td>N/A</td> </tr> <tr> <td>Gravity Air Inlet</td> <td>N/A</td> <td>N/A</td> <td>12 (30)</td> </tr> <tr> <td>Forced Air Inlet Within 10 ft. (3.0 m)</td> <td>N/A</td> <td>N/A</td> <td>36 (91)</td> </tr> <tr> <td>Grade</td> <td>N/A</td> <td>N/A</td> <td>12 (30)</td> </tr> <tr> <td>Gas &amp; Electric Meters, Regulators &amp; Relief Valves</td> <td>N/A</td> <td>48 (122)</td> <td>N/A</td> </tr> </tbody> </table>				BELOW Inches (cm)	HORIZONTAL Inches (cm)	ABOVE Inches (cm)	Door	N/A	48 (122)	N/A	Window	48 (122)	12 (30)	N/A	Gravity Air Inlet	N/A	N/A	12 (30)	Forced Air Inlet Within 10 ft. (3.0 m)	N/A	N/A	36 (91)	Grade	N/A	N/A	12 (30)	Gas & Electric Meters, Regulators & Relief Valves	N/A	48 (122)	N/A
	BELOW Inches (cm)	HORIZONTAL Inches (cm)	ABOVE Inches (cm)																												
Door	N/A	48 (122)	N/A																												
Window	48 (122)	12 (30)	N/A																												
Gravity Air Inlet	N/A	N/A	12 (30)																												
Forced Air Inlet Within 10 ft. (3.0 m)	N/A	N/A	36 (91)																												
Grade	N/A	N/A	12 (30)																												
Gas & Electric Meters, Regulators & Relief Valves	N/A	48 (122)	N/A																												
<ul style="list-style-type: none"> <li>Use a factory supplied 4 in. (10.2 cm) Vent Pipe Adaptor to connect venting to exhaust end of tube. Use RTV silicone adhesive sealant and three (3) self-drilling screws to attach. See the OVERVIEW DRAWINGS section for more venting information.</li> </ul>	<p><b>MAXIMUM LENGTHS OF VENT PIPE</b></p> <table border="1" data-bbox="844 1745 1429 1801"> <tbody> <tr> <td>40 TO 125 MBTUH (12 – 37 kW)</td> <td><b>35</b> linear ft. (10.7 m)*</td> </tr> <tr> <td>130 TO 200 MBTUH (38 – 59 kW)</td> <td><b>40</b> linear ft. (12.2 m)*</td> </tr> </tbody> </table> <p>*Each 90 degree elbow inserted in the venting system is equivalent to 10 linear ft. (3.0 m). *Each 45 degree elbow inserted in the venting system is equivalent to 5 linear ft. (1.5 m). A maximum of <b>two</b> 90 degree elbows or their equivalent are allowed (e.g. one 90 degree elbow plus two 45 degree elbows; or four 45 degree elbows, etc.)</p>			40 TO 125 MBTUH (12 – 37 kW)	<b>35</b> linear ft. (10.7 m)*	130 TO 200 MBTUH (38 – 59 kW)	<b>40</b> linear ft. (12.2 m)*																								
40 TO 125 MBTUH (12 – 37 kW)	<b>35</b> linear ft. (10.7 m)*																														
130 TO 200 MBTUH (38 – 59 kW)	<b>40</b> linear ft. (12.2 m)*																														

# WINDY CONDITIONS NOTES

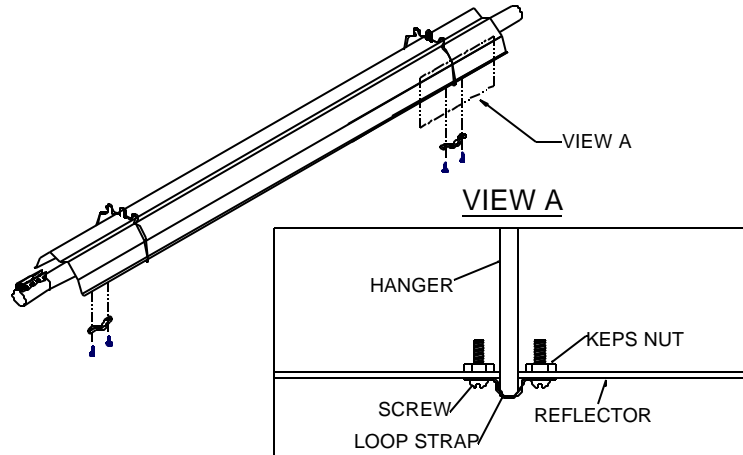
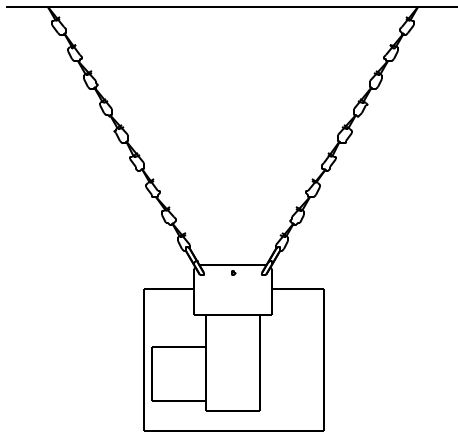

NEAR LOADING DOCK, AIRPLANE HANGAR DOORS, OR OTHER WINDY AREAS FASTEN REFLECTORS TO HANGERS WITH LOOP STRAPS, SCREWS AND KEPS NUTS.

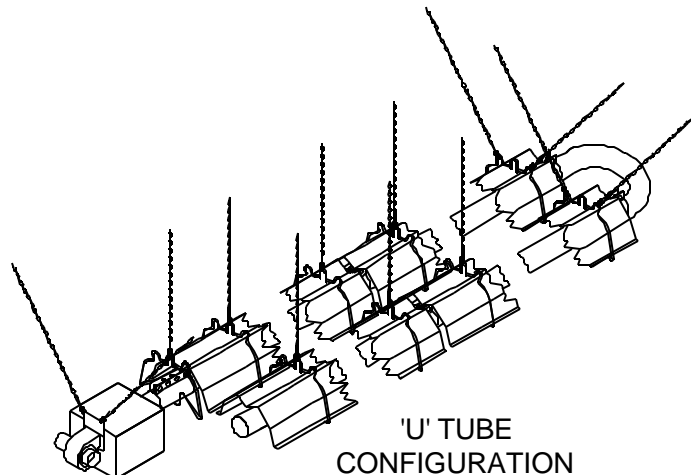
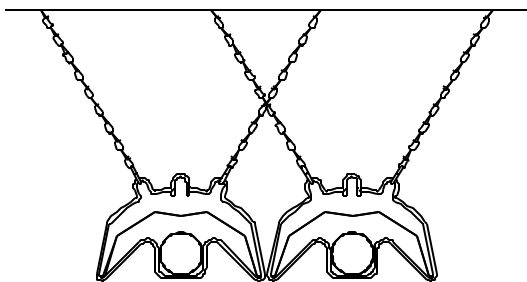
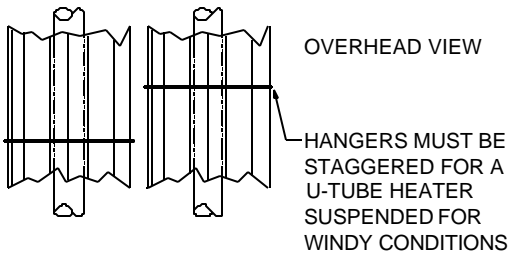
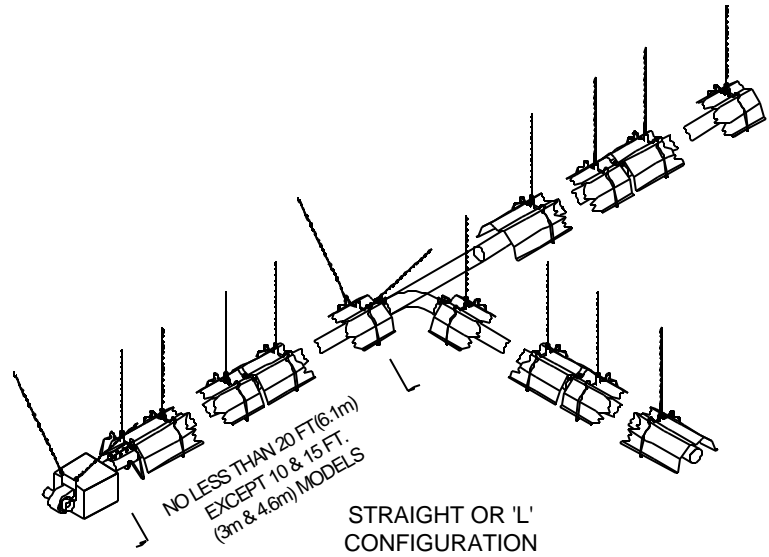
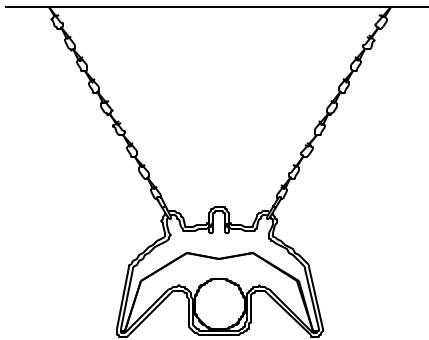

## U-TUBE INSTALLATION

- A heater may be installed as a U-Tube with its radiant tubes horizontal or with the heat exchanger angled above the combustion chamber as illustrated by the drawing below.
- When radiant tubes are horizontal, reflectors may be individually rotated from 0 to 30 degrees or from 0 to 45 degrees depending on the model installed. (Refer to CLEARANCE TO COMBUSTIBLES section).

### HORIZONTAL

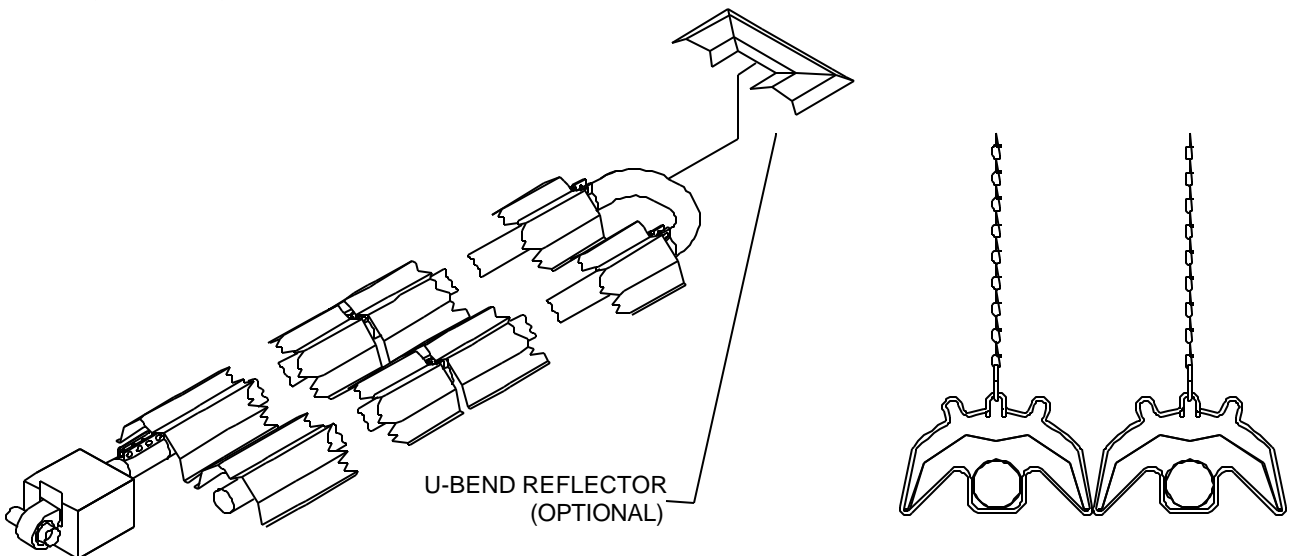

### ANGLED

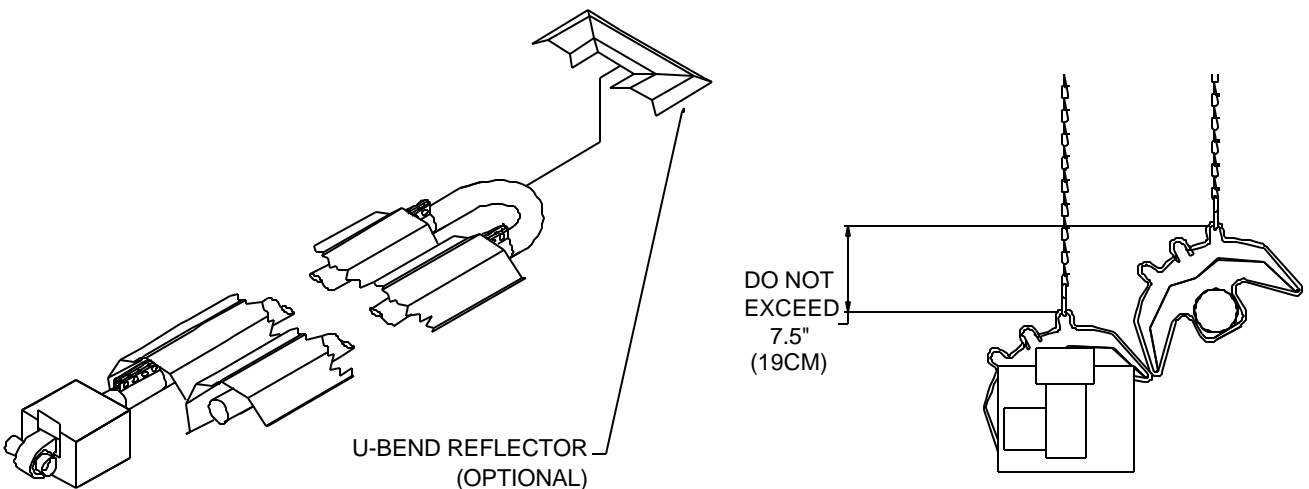

## INSTALLATION (1 OF 2)

### CAUTION

- **DO NOT** use gas piping or electrical conduit to provide any type of support for the heater's suspension.
- Means of suspension **MUST BE** able to support twice the weight of the heater, securely fastened to the building's structure, and allow for expansion during its operation.
- Chain for suspension **MUST BE** 12 in. (31cm) minimum in length and be 1/0 TENSO with a minimum working load rating of 200 lbs. (90.7 kg).
- The "S" hook **MUST BE** Chicago Hardware no. 5 or equal and carry a 70 pound (32kg) maximum load.

**STEP**  
**1**

- Use a taut string in the planning of suspension points to maintain straightness over the length of the system. Make true right angles if elbows are used.
- Check the BASIC SYSTEM CONFIGURATIONS section for the general orientation of components matching the model number of your system.
- Identify all components in the COMBUSTION CHAMBERS and HEAT EXCHANGERS sections.
- U-type systems use a 180-degree U-bend. See U-TUBE INSTALLATION section.

**STEP**  
**2**

- Install chain for suspension of tubes and reflectors.
- The suspension points for each 10-foot (3.0m) tube should be a minimum of 4 feet (1.2m) and a maximum of 8 feet (2.4m) apart.
- Install a chain to be positioned at the joint between the combustion chamber and the burner.
- Install an additional suspension point, for a required safety chain at the back of the burner box 17.5 in. (44cm) from the joint between the combustion chamber and the burner. The burner safety chain should have an additional 6 in. (15cm) of length added to allow for slack.
- Install tube/reflector hangers. Slip one end of the S-hook through the last chain link and the other end through the tube/reflector hanger.
- **IMPORTANT: Crimp both ends of the S-hook closed!**

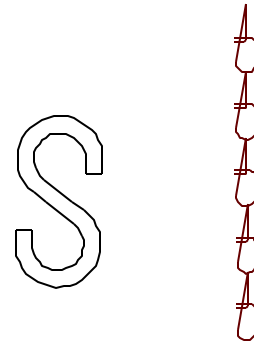

**STEP**  
**3**

- Lift the exhaust end heat exchanger [or combustion chamber C9 on a 40 MBTUH (11.7 kW) 10-foot (3.0 m) unit] into place with the weld seam facing up and suspend it in the tube/reflector hangers already in position. The exhaust end heat exchanger is marked "EXHAUST END" except for a 40 MBTUH (11.7 kW) 15-foot (4.6 m) unit where the last 5-foot (3.0 m) tube H6 is unmarked. The designation of the exhaust end tube (H5, H6, H9 or H1) is determined by burner size and system length as per the BASIC SYSTEM CONFIGURATIONS section.

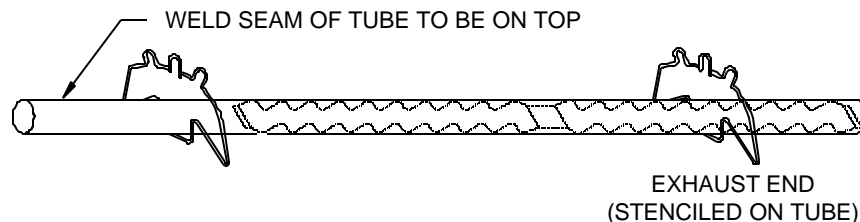

**STEP**  
**4**

- Install a tube clamp on the end **opposite** of the end marked "EXHAUST END". Orient clamp bolts on top.
- **Make sure the tube is inserted tight against the center stop inside the tube clamp.**
- Install factory supplied 4 in. (10.2 cm) Vent Pipe Adaptor onto the end of the tube stenciled "EXHAUST END". Use RTV silicone adhesive sealant and three (3) self-drilling screws to attach.
- Finish installing exhaust venting.

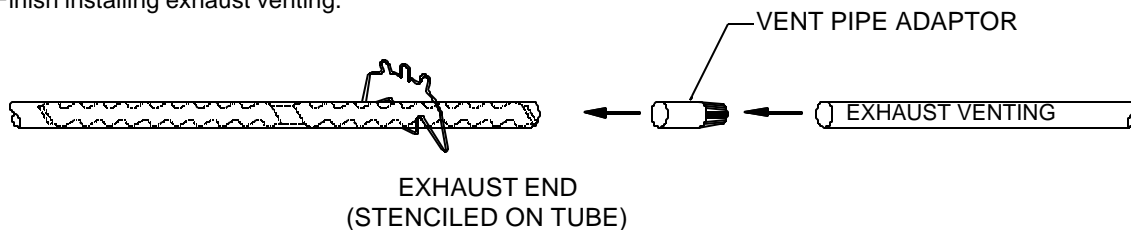

### CAUTION: MB & MC SERIES

- All burner covers are yellow, except for the MB and MC Series, which are white. The MB or MC burner **must be used with an H9 heat exchanger**, which has a **piece of white tape** at the exhaust end (**NO EXCEPTIONS**). Improper operation may result if this is not followed.

## INSTALLATION (2 OF 2)

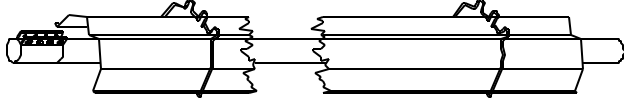
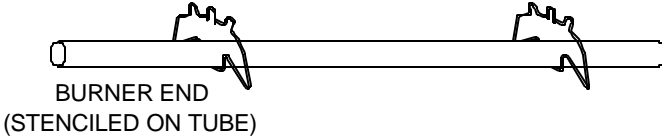
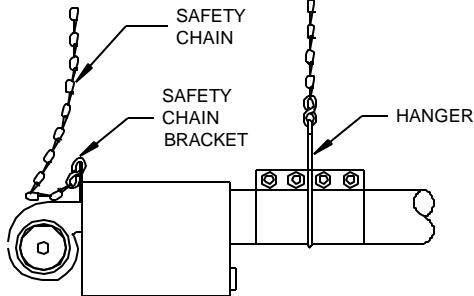
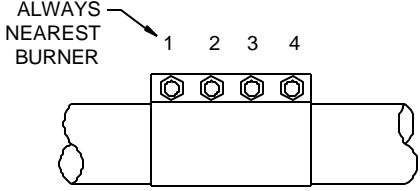
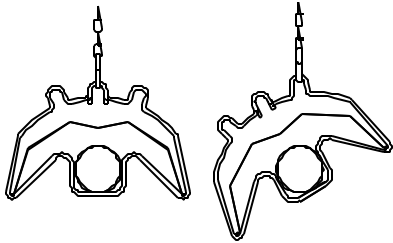
<b>STEP</b> <b>5</b>	<ul style="list-style-type: none"> <li>Lift the remaining heat exchanger(s), for heaters longer than 25 feet (7.6 m), into place with the weld seam facing up in the tube/reflector hangers previously installed.</li> <li>Insert the end of the tube into the tube clamp of the previously hung heat exchanger. Be certain that the tube is inserted to the stop inside the tube clamp.</li> <li>Tighten the tube clamp, sufficiently but not permanently, to make sure it does not come loose during installation.</li> <li>Install a tube clamp on the end of each heat exchanger after it is installed.</li> <li>Install the reflector(s) inside the hangers. (Gloves are suggested so as not to soil the shiny underside.)</li> </ul>	
		
<b>STEP</b> <b>6</b>	<ul style="list-style-type: none"> <li>Lift the combustion chamber, for heaters of 20 feet (6.1 m) or more, into place with the weld seam facing up in the tube/reflector hangers previously installed so that the end of the tube stenciled "BURNER END" is where the burner will be installed. The combustion chamber is aluminized steel [C2, C3, (C4 painted black)] or black steel (C1).</li> <li>Insert the other end into the tube clamp on the previous heat exchanger. Be certain that the tube is inserted to the center stop in the clamp.</li> <li>Tighten the tube clamp, sufficiently but not permanently, to make sure it does not come loose during installation.</li> <li>Install a tube clamp on the burner end of the combustion chamber after it is installed.</li> <li>Install the reflector inside the hangers. (Gloves are suggested so as not to soil the shiny underside.)</li> </ul>	
		
<b>STEP</b> <b>7</b>	<ul style="list-style-type: none"> <li>Install a tube/reflector hanger around the center of this tube clamp on the burner end of the combustion chamber. This hanger will provide the main support for the burner.</li> <li>Lift the burner into place and suspend it by inserting the S-hook of the safety chain into the center hole of the safety chain bracket, and then crimp both ends of the hook closed.</li> <li>Insert the burner tube into the tube clamp at the burner end of the combustion chamber. Make sure the burner tube is inserted against the center stop inside of the tube clamp. The safety chain for the burner has 6" (15 cm) of slack. It is <b>NOT</b> taut. Then, tighten the clamp as described in step 8.</li> </ul>	
<b>STEP</b> <b>8</b>	<ul style="list-style-type: none"> <li>Tighten all tube clamp bolts on all tube clamps to 65 ft.-lbs. (88 Nm) with a torque wrench in a 2, 3, 4, 1 sequence where #1 is always closest to the burner. See OVERVIEW DRAWINGS section for more information.</li> </ul>	
<b>STEP</b> <b>9</b>	<ul style="list-style-type: none"> <li>Reflectors must not be angle mounted more than 30° from horizontal for 65 to 125 MBTUH (19 – 37 kW) or 45° from horizontal for 40 to 60 or 130 to 200 MBTUH (12 – 18 or 38 – 59 kW). <b>If located near a door or windy area, fasten reflectors to tube/reflector hangers with sheet metal screws or other positive means. See WINDY CONDITION NOTES.</b></li> </ul>	

<b>CAUTION</b>	<b>IMPORTANT</b>
<ul style="list-style-type: none"> <li>Make sure all chains are plumb and vertical to prevent damage to tubes.</li> </ul>	<ul style="list-style-type: none"> <li>Connect the gas supply as instructed in the GAS SUPPLY AND GAS PRESSURE section.</li> <li>Connect the electrical supply as instructed in the ELECTRICAL SUPPLY AND THERMOSTATIC CONTROL section.</li> </ul>

# ELECTRICAL SUPPLY AND THERMOSTATIC CONTROL (1 OF 2)

ELECTRICAL SUPPLY	120 VAC THERMOSTATIC CONTROL
<ul style="list-style-type: none"> <li>Voltage: 120VAC- 1 phase- 60 Hz.</li> <li>Maximum Amps: 3.0 (1.33 actual full load amps).</li> <li>Flame safety: Electronic.</li> <li>Ignition: Direct Spark.</li> <li>Wiring must conform to the latest edition of the National Electric Code (ANSI/NFPA 70) or local code legally authorized.</li> <li>Electrical power takeoff must be connected to a separately fused circuit with a disconnect, and must be properly polarized and grounded to the heaters power cord.</li> <li>Do not run wiring over the heaters or in direct view of radiant heat.</li> <li>If any of the wiring supplied must be replaced use type 16 AWG (1.0mm<sup>2</sup>), or equivalent with 2/64" (.08 cm) insulation and a minimum insulation temperature of 302°F (150°C).</li> </ul>	
<b>CAUTION – 24VAC THERMOSTAT</b>	<b>24 VAC THERMOSTAT AND TRANSFORMER</b>
<p>DO NOT try to connect more than three burners to a 24 VAC thermostat. The transformer relay is rated to operate only three heaters safely. Failure to do so may cause serious bodily harm or property damage.</p>	
<b>SEQUENCE OF OPERATION</b>	<b>BURNER WIRING SCHEMATIC/INTERCONNECTION DIAGRAM</b>
<ul style="list-style-type: none"> <li>Thermostat calls for heat.</li> <li>120 VAC is applied to the blower and validation light PL-1 indicates power is ON.</li> <li>Air flow switch closes contacts after it senses an increase in air pressure due to fan reaching operational speed.</li> <li>Validation light PL-2 indicates combustion air supply and exhaust venting back pressure is normal.</li> <li>Ignition Detection Control (IDC) is turned on and begins a pre-purge time period.</li> <li>A spark is developed at the igniter and the gas valve is opened to the first step of its two step operation.</li> <li>Burner ignites and 5 seconds later the gas valve steps up to its operating position. DC electrical current flows from sensing electrode through flame to ground.</li> <li>IDC senses flame presence, turns OFF spark, gas continues flowing through valve.</li> <li>Validation light PL-3 indicates normal burner operation.</li> <li>During first trial-for-ignition period or upon any flame outage at sensing electrode, the IDC responds and begins sparking within 0.8 seconds. A 15-second trial-for-ignition period begins to re-light the burner. If flame is re-established, normal operation resumes. If the burner does not light after first try, the inter-purge sequence is completed between trials to re-light the burner. If the burner fails to light (10DX-117) or after third trial (35-725), IDC will de-energize the valve and go into lockout mode.</li> <li>For lockout recovery, reset thermostat below ambient temperature or disconnect electrical power supply for five (5) seconds.</li> </ul>	<p>If any of the original wire as supplied with the appliance must be replaced, it must be replaced with wiring material having a temperature rating of at least 302°F (150°C) and shall have a minimum size of 16 AWG.</p>

# ELECTRICAL SUPPLY AND THERMOSTATIC CONTROL (2 OF 2)

## SEQUENCE OF OPERATION (CONT'D)

- If the flame does fail during ignition or normal operation, it is detected by the flame sensor rod, and the IDC then closes the gas valve locking out the system until the thermostat is cycled to the OFF position.
- When the thermostat is satisfied, the whole system is de-energized until another call for heat.
- When installing or servicing this heater, wait at least 5 minutes between attempts for ignition.

## GENERAL INSTALLATION NOTES

- Locate the thermostat as specified in the heating plan.
- If it is not in the heating plan, follow the instructions provided with the thermostat.
- If instructions are not provided with the thermostat, locate it four to five feet above the floor where it will not be directly affected by the heat from the heater, outside drafts, or the sun.
- A location that best represents the average temperature of the room is the most desirable.
- If two heaters are installed on a common exhaust vent they must be controlled by the same thermostat.

## MAXIMUM NUMBER OF HEATERS FOR OPTIONAL THERMOSTATS

Part No.	Volts AC	Amps	Number of Heaters
132026-4	120	22.0	7
132486	120	16.0	5
0002-42-157	120	16.0	5
132700	24	.15-1.0	3*
0002-42-122	24	2.5	3*
0002-42-121	24	1.5	3*

\* When installing a Low-Intensity heater to any thermostat, the installer should allow for 3 amps per heater as the blower tends to use more electricity than its rating during its start-up period. This is why all of the 24 VAC thermostats must be connected to a 120 VAC transformer relay, which will safely support only three heaters.

## BURNER WIRING LADDER DIAGRAM

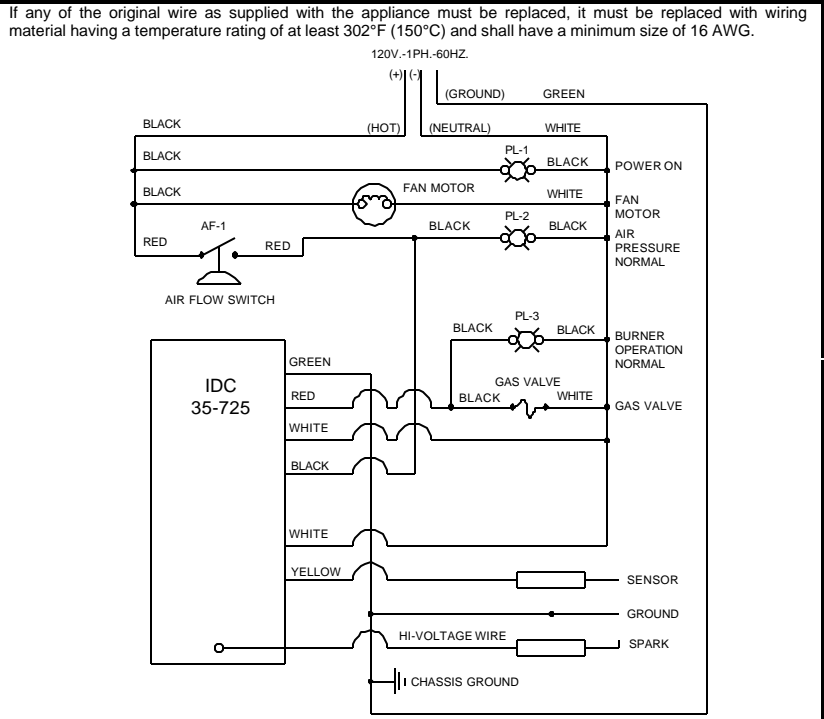

## HEATERS IN SERIES WITH A 120 VAC THERMOSTAT

NOTE: SEE TABLE FOR MAXIMUM NUMBER OF HEATERS ON A THERMOSTAT

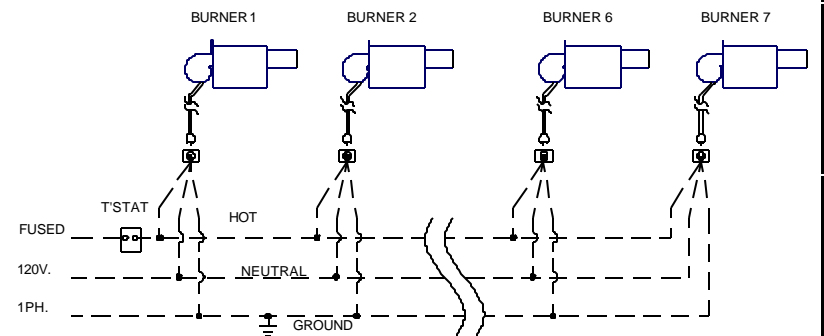

## HEATERS IN SERIES WITH A 24 VAC THERMOSTAT

NOTE: BROWN WIRE IS NOT USED BUT MAY BE ELECTRICALLY HOT. PROTECT PERSONNEL AND THE CIRCUIT BY SCREWING ON A WIRE NUT

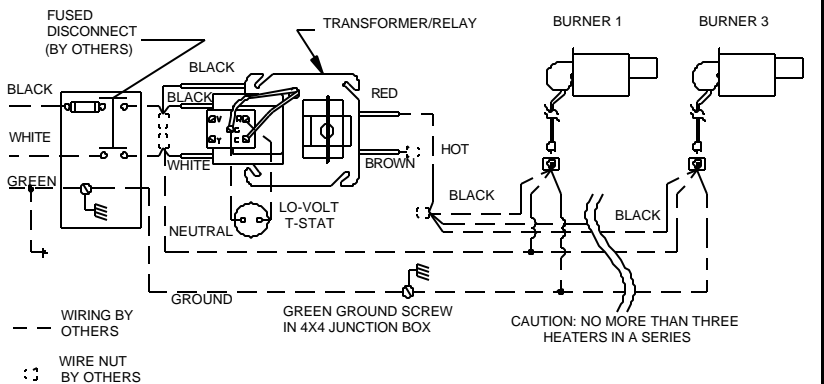

# GAS SUPPLY AND GAS PRESSURE

GAS SUPPLY PIPING				INLET GAS PRESSURE					
<ul style="list-style-type: none"> <li>Piping must be installed in accordance with local codes and/or ANSI Z223.1-latest edition (NFPA 54-latest edition), National Fuel Gas Code.</li> <li>Piping must have drip leg and a ground joint union.</li> <li>All pipe connections must have pipe joint compound, resistant to LP/propane gas action.</li> <li>Isolate regulators, flexible gas connectors, and heaters during high-pressure leak testing.</li> <li>All gas lines must be purged before startup.</li> <li>Use only agency approved flexible gas connector with shut-off cock for connecting to heater. (SEE CAUTION)</li> <li>Use swing or swivel joint in addition to rigid piping if local codes prohibit use of a flexible gas connector.</li> <li>Local codes may require additional shut-off cock ahead of the drip leg.</li> </ul>				<ul style="list-style-type: none"> <li>Inlet gas pressure must be measured on the inlet side of the valve at Test Point 'A' in the supply piping and must conform to the following:</li> </ul>					
				GAS TYPE	RATING MBTUH (kW)	PRESSURE In. WC (cm WC)			
				<b>MINIMUM:</b>					
				NATURAL GAS	40 to 125 (12 to 37)	6 (15)			
				NATURAL GAS	130 to 200 (38 to 59)	7 (18)			
<b>MAXIMUM:</b>									
LP/PROPANE GAS		ALL	11 (28)						
NATURAL GAS LP/PROPANE GAS		ALL	14 (35)						
<b>CAUTION: "LAZY LOOP"</b>									
<ul style="list-style-type: none"> <li>Stress from expansion and contraction of heater may cause excessive wear on the gas connection.</li> <li>If local codes permit, flexible gas connectors must be in a "Lazy Loop", arrangement as shown on drawing below.</li> <li>It is important to maintain dimensions on drawing below.</li> </ul>									
Heater length	Expansion	Heater length	Expansion	<b>IMPORTANT</b>					
10-20 ft (3.1-6.1 m)	1.1 in (2.8 cm)	45-50 ft (13.7-15.2 m)	2.1 in (5.3 cm)				<ul style="list-style-type: none"> <li>Gas pressure at Test Point 'A' cannot be more than 14 inches of water column (in. WC) (½PSI) (35 cm WC), confirmed by actual field test. (Heater on or off)</li> </ul>		
25-30 ft (7.6-9.1 m)	1.5 in (3.8 cm)	55-60 ft (16.8-18.3 m)	2.4 in (6.1 cm)						
35-40 ft (10.7-12.2 m)	1.8 in (4.6 cm)	65-70 ft (19.9-21.3)	2.7 in (6.7 cm)						
<b>HIGH INLET GAS PRESSURE</b>				<ul style="list-style-type: none"> <li>For pressure greater than 14 in. WC (35 cm WC) a positive lockout type high-pressure regulator must be installed in the gas line ahead of the burner.</li> <li>Always check local codes for gas venting requirements for high-pressure regulators.</li> <li>Over-protection pressure devices (OPD's) may be required in certain jurisdictions.</li> <li>High inlet gas pressure regulators will <b>NOT</b> turn off the flow of gas.</li> </ul>					
GAS PRESSURE MEASUREMENTS							MANIFOLD OUTLET GAS PRESSURE		
<ul style="list-style-type: none"> <li>Use only water or red oil manometer to make measurements – NOT A DIAL GAUGE.</li> <li>Make <b>ALL</b> measurements and adjustments when this heater and <b>ALL</b> other gas burning equipment connected to the same gas meter are operating at maximum capacity.</li> </ul>							<ul style="list-style-type: none"> <li>Fluctuations in inlet pressure can alter manifold pressure.</li> <li>For manifold pressure adjustment locations, refer to drawing below.</li> <li>Remove pipe plug from Test Point 'B'; insert a barb fitting connected to the manometer.</li> <li>For all heaters remove the slotted cap screw.</li> <li>Turn adjustment screw clockwise to increase pressure or counterclockwise to decrease pressure. Screw may require a flat head screwdriver or a 3/32" (2.38mm) hex key.</li> </ul>		
				40 to 100 (12 to 29)	3.5 in. WC (8.9 cm WC) (Nat./LP)				
105 to 200 (31 to 59)	5.0 in. WC (12.7 cm WC) (Nat./LP)								
<p>WHEN GAS PRESSURE EXCEEDS 14" W.C. (35 CM W.C.) A FIRST STAGE REGULATOR MUST BE INSTALLED.</p> <p>LOCAL CODES MAY REQUIRE AN ADDITIONAL SHUT-OFF COCK BE INSTALLED IN THE GAS LINE AHEAD OF THE DRIP LEG</p> <p>DRIP LEG</p> <p>GAS COCK (SUPPLIED BY OTHERS)</p> <p>1/2" (1.27 CM) O.D. FLEXIBLE GAS CONNECTOR 24" (61 CM) LONG STAINLESS STEEL</p> <p>RECOMMENDED GAS CONNECTION ARRANGEMENT USING A FLEXIBLE GAS CONNECTOR</p>				<p>SAFETY CHAIN</p> <p>MANIFOLD PRESSURE ADJUSTMENT (ROBERT SHAW VALVE)</p> <p>MANIFOLD PRESSURE ADJUSTMENT (WHITE RODGERS VALVE)</p> <p>TEST POINT 'A' (INLET)</p> <p>TEST POINT 'B' (OUTLET)</p>					
							CAUTION		
<p>Excessive torque on the burner gas inlet manifold pipe may cause damage to burner. Always use two (2) wrenches when making pipe connections. Important: Check for leaks with soap solution. <b>DO NOT USE FLAMES!</b> Leak test solution may cause corrosion. After test, water rinse to clear out any remaining solution.</p>									

# STARTUP

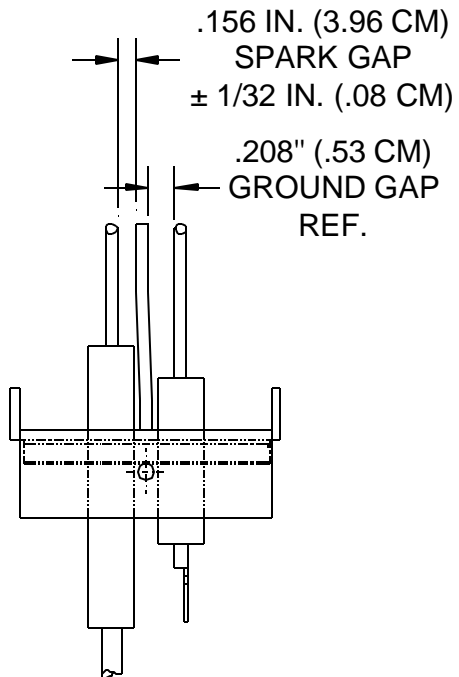
STARTUP	IMPORTANT
<ul style="list-style-type: none"> <li>Remove the burner cover by removing the 4 sheet metal screws from the topside of the burner cover.</li> <li>Remove the 1/8 NPT pipe plug from Test Point B and connect manometer. Refer to the drawing in the GAS SUPPLY AND GAS PRESSURE section.</li> <li>Depress the dial on the gas valve, and make sure the gas valve is in the ON position.</li> <li>Turn on the electrical and gas supply and set the thermostat above the ambient room temperature, to call for heat.</li> <li>Refer to the ELECTRICAL SUPPLY AND THERMOSTATIC CONTROL section for proper sequence of operation.</li> <li>If the heater does not operate normally, refer to the BURNER TROUBLESHOOTING section to diagnose and correct the situation.</li> <li>Turn gas and electrical supply off, remove the manometer and replace the 1/8 NPT pipe plug into Test Point B on the gas valve.</li> <li>Check again for gas leaks. Refer to GAS SUPPLY AND GAS PRESSURE section as needed.</li> <li>Cycle the heater several times by means of the thermostat, allowing at least five minutes between cycles. If the heater operates normally, replace the burner cover and screws.</li> <li>If the heater is vented directly outdoors, observe and verify the flue gases exiting from the exhaust vent are not impinging on building construction.</li> </ul>	<ul style="list-style-type: none"> <li>Check and, if necessary, adjust the manifold pressure!</li> </ul>  <p>.156 IN. (3.96 CM) SPARK GAP ± 1/32 IN. (.08 CM)</p> <p>.208" (.53 CM) GROUND GAP REF.</p>

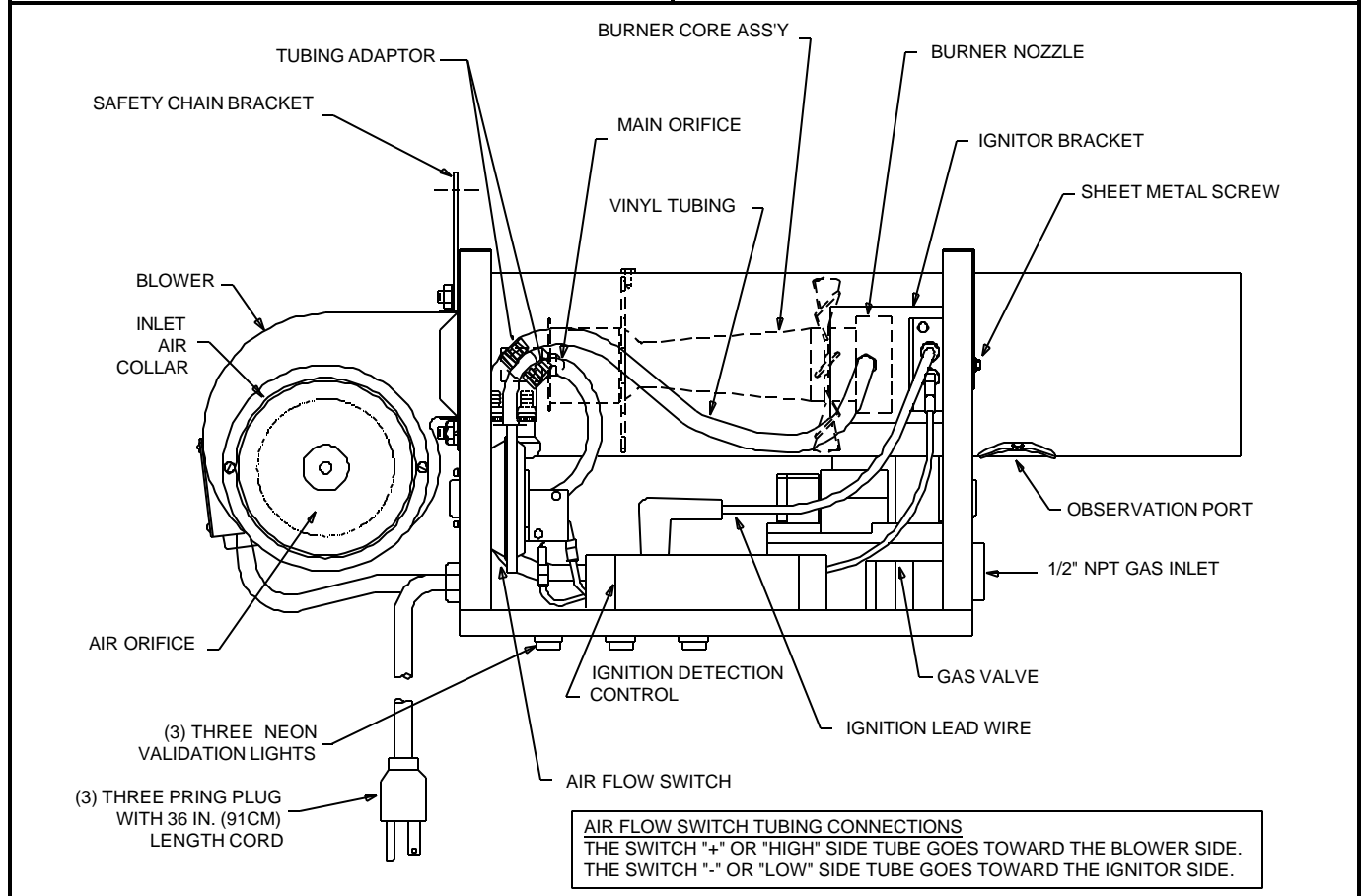

## MAINTENANCE

- **FOR SAFETY REASONS, BEFORE PERFORMING ANY MAINTENANCE, DISCONNECT AND LOCKOUT THE ELECTRICAL SUPPLY, INCLUDING THE THERMOSTAT, BY POSITIVE MEANS.**
- All maintenance and/or repair **MUST** be performed by someone trained and qualified to work on gas and electrical equipment.
- Annual maintenance done prior to the beginning of each heating season is all that is usually necessary.
- In dirty, dusty, or wet atmospheres, it may be necessary to examine and perform needed maintenance at additional times during the middle of the heating season. Experience will dictate the frequency.
- Radiant tubes, combustion air ducting, and exhaust venting should be inspected to make sure that: suspension points are secure, tube clamp nuts are tight, heater is level, chains are plumb and taut (except for burner safety chain), vent pipe joints are properly sealed, "S" hooks are crimped closed, there is no excessive exterior buildup of dust or dirt, and make sure there are no restrictions such as bird or insect nests in the combustion air or vent piping or their terminations.
- Reflectors should be inspected to make sure they are clean and secure, as detailed in the INSTALLATION section. If dirty, reflectors should be removed and washed with isopropyl alcohol, Simple Green, or buffed with mild rubbing compound.
- On U-tube systems, the U-bend reflector support nuts should be inspected to make sure they are tight.
- Inspect the inside of the blower housing for excessive dust or dirt buildup on the impeller wheel and make sure the air orifice and the inlet air collar are properly attached. Check that the blower can come up to full speed.
- Remove the cover by removing the 4 sheet metal screws on top of the cover.
- Remove the ignitor by removing **ONLY** the end where the vinyl tubing is attached to the ignitor bracket; the fitting to which the vinyl tubing was connected; the ignition lead wire from the ignition detection control; and the sheet metal screw holding the ignitor bracket to the burner housing wall.
- Remove the ignitor carefully; its' electrodes make a ninety degree turn to the right.
- Clean the ignitor's porcelain insulation and check for cracks and proper gaps (see STARTUP section).
- Within the interior of the burner tube, examine the burner nozzle, primary air holes, main orifice and surrounding area for build up of dust or dirt. Clean if necessary.
- Reinstall the ignitor by following the previous instructions in reverse order.
- Examine the ignition detection control for overheating (warped plastic housing, discoloration, etc.)
- A visual inspection of gas valve, airflow switch, and wiring is adequate.
- Inside each clear vinyl tube used for air flow sensing is a small snubber (aluminum cylinder piece). Visually inspect for cleanliness.
- Clean any surfaces needed and correct any situations found in disrepair.
- Replace the cover and sheet metal screws.
- The blower motor is of the permanently lubricated type and requires no additional lubrication.
- Double check that the area under the heater is kept clear and free from combustible materials, gasoline, and other flammable vapors and liquids.
- Reconnect electrical supply and cycle the heater several times using the thermostat allowing (5) five minutes between cycles for proper operation.
- **WARNING: Do not operate heater with any part bypassed, with any part failed or in any possible situation that may compromise safety. Personal injury, death, and/or property damage could result.**

## TROUBLESHOOTING

Check for symptoms and possible causes in the order presented from the top of this chart to the bottom. The symptoms and possible causes are in a logical progressive order as in a flow chart.		
SYMPTOM	POSSIBLE CAUSE	CORRECTIVE ACTION
<b>New Installation.</b>	1. Heaters not isolated during high pressure leak testing.	1. Replace combination gas valves on each heater.
	2. All gas lines not completely bled of air.	2. Disconnect flex hose at each heater until gas is present. Connect flex hose and leak test.
	3. Gas supply regulator reversed.	3. Remove and install properly.
<b>Gas Odor.</b>	1. Gas pipe joints loose.	1. Check joints with soap solution, tighten as needed.
<b>Blower / PL-1 light does not come on when system energized.</b>	1. Power supply fuse defective.	1. Replace fuse.
	2. 115 VAC not reaching heater.	2. Check thermostat and wiring and fix.
	3. Blower defective.	3. Replace blower.
<b>Pressure switch does not close / PL-2 light does not come on.</b>	1. Inlet or exhaust piping not the proper size and length. (Refer to manual.)	1. Replace piping as required.
	2. Inlet or exhaust termination fittings not to factory specifications.	2. Replace fittings as required.
	3. Inlet or exhaust blocked.	3. Clear blockage.
	4. Airflow tubing or snubber orifice blocked in one or both tubes.	4. Clear blockage.
	5. Blower wheel dirty or damaged.	5. Clean or repair wheel.
	6. Airflow pressure switch defective.	6. Replace airflow pressure switch.
<b>Ignitor does not spark / PL-3 light does not come on.</b>	1. 115 VAC not reaching the Ignition Detection Control (IDC) due to loose wire or connector.	1. Repair loose wire or connector.
	2. High-voltage wire loose or damaged.	2. Secure high-voltage wire or replace ignitor.
	3. Ignition Detection Control (IDC) defective.	3. Replace IDC box.
<b>Burner does not ignite. (There are three trials-for-ignition before the IDC goes into lockout).</b>	1. Gas supply not turned on.	1. Open all manual gas supply valves.
	2. Ignitor not sparking at the tips.	2. Measure spark gap and adjust gap as necessary to 5/32" [0.156" (3.96mm)].
	3. Ignitor not sparking at correct gap.	3. Replace ignitor.
	4. Gas inlet pressure not correct. (See serial plate). Gas inlet piping not sized correctly.	4. Replace inlet gas piping with correct size pipe.
	5. Gas inlet pressure not correct. (See serial plate). Gas supply regulator not set correctly.	5. Adjust gas supply regulator to set inlet pressure to proper level. (See serial plate).
	6. Gas supply regulator sticking.	6. Replace gas supply regulator.
	7. Combination gas valve not in the ON position.	7. Turn combination gas valve to the ON position.
	8. Ignition Detection Control (IDC) not sending 115VAC to combination gas valve.	8. Replace IDC box.
	9. Combination gas valve defective.	9. Replace combination gas valve.
	10. Combination gas valve outlet (manifold) pressure not correct. (See serial plate).	10. Adjust combination gas valve regulator to set inlet (manifold) pressure to proper level.
	11. Main or sub gas orifice blocked by spider web, etc.	11. Clear blockage.
	12. Gas orifice(s) or air orifice not correct size.	12. Install correct size gas orifice(s) or air orifice.
<b>Spark does not stop when the burner ignites.</b>	1. Power supply not grounded to a true earth ground.	1. Install a true earth ground to the power supply.
	2. Flame sensor wire loose or damaged.	2. Secure flame sensor wire or replace wire harness to IDC box.
	3. Flame signal not at least -17 VDC.	3. Check gas inlet and manifold pressures compared to the possible causes in the previous symptom where the burner does not ignite.
	4. Ignition Detection Control (IDC) is defective.	4. Replace IDC box.
<b>Burner does not stay lit until the thermostat is satisfied.</b>	1. Flame sensor wire is loose or damaged.	1. Replace wire harness to IDC box.
	2. Inlet or exhaust partially blocked.	2. Clear blockage.
	3. Airflow pressure switch erratic or defective.	3. Consult factory or replace airflow pressure switch.
	4. Flame signal not at least -17 VDC.	4. Check gas inlet and manifold pressures compared to the possible causes in the previous symptom where the burner does not ignite.
	5. Ignition Detection Control (IDC) defective.	5. Replace IDC box.
<b>Heater will not turn off.</b>	1. Thermostat defective.	1. Replace thermostat.

## REPLACEMENT PARTS

### **! WARNING !**

Any substitutions of factory-installed parts without prior written permission may result in unsafe operation, property damage, personal injury, death, voids CSA design certification, and manufacturer's warranty.

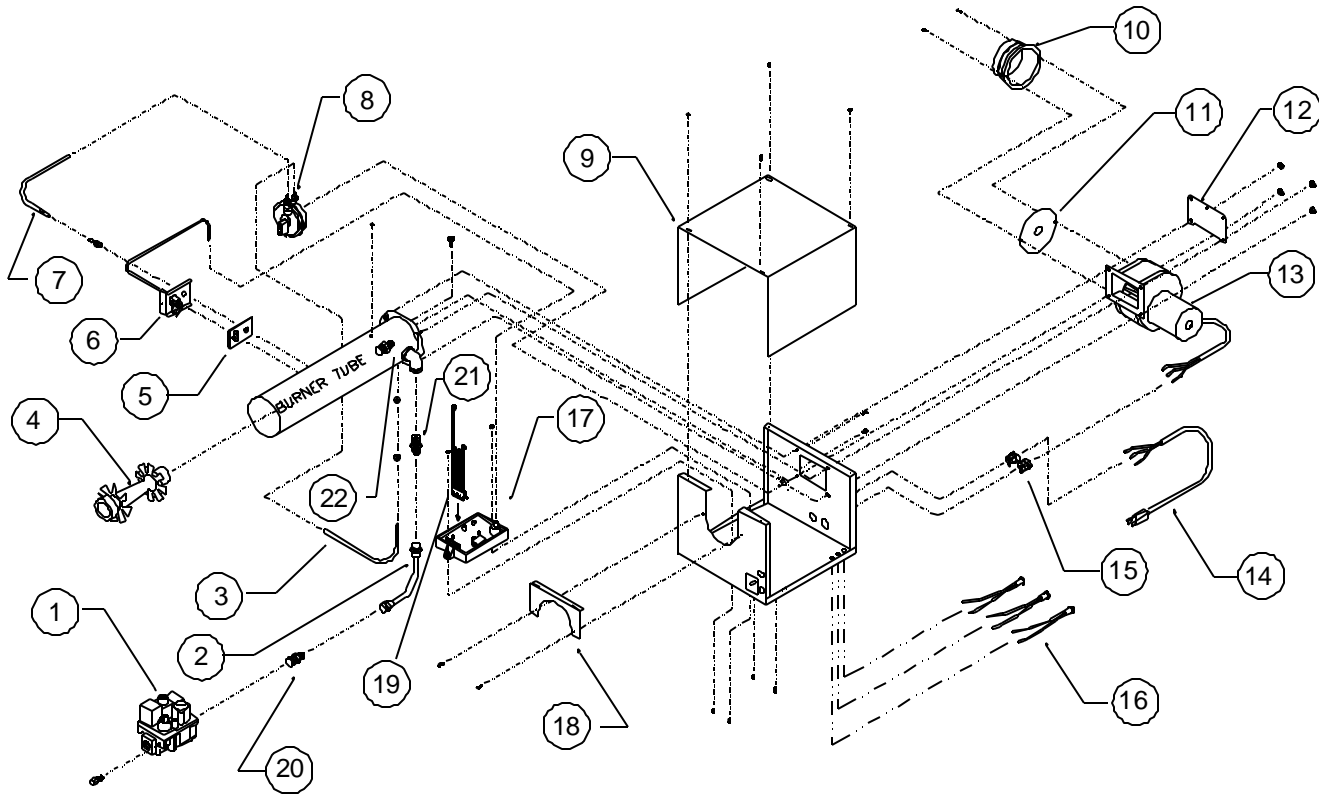

1. Gas valve	12. Safety chain bracket with nuts
2. Gas manifold assembly with fittings	13. Blower motor
3. Air flow switch (combustion) tubing assembly with snubber and fittings	14. 36" (91cm) long power cord with 3-prong grounded plug
4. Burner core	15. Power cord strain relief bushing
5. Ignitor gasket	16. System validation light
6. Ignitor	17. Ignition detection control
7. Air flow switch (exhaust) tubing assembly with snubber and fittings	18. Burner tube holding bracket with screws
8. Air flow switch	19. Wire harness assembly
9. Burner cover	20. Gas manifold fitting (at valve)
10. Inlet combustion air collar	21. Gas sub orifice
11. Air orifice plate	22. Gas main orifice (located inside of burner tube)

**Due to continuous product improvement, please provide serial and model number prior to ordering replacement parts to assure safe repairs and maintenance.**

THIS PAGE INTENTIONALLY LEFT BLANK

**FOR SERVICE OR REPAIR, FOLLOW THESE STEPS IN ORDER:**

**FIRST:** Contact the Installer

Name \_\_\_\_\_

Address \_\_\_\_\_

\_\_\_\_\_

\_\_\_\_\_

Phone \_\_\_\_\_

**SECOND:** Contact the Nearest Distributor

Model No.: \_\_\_\_\_

Unit Serial No.: \_\_\_\_\_

Date of Installation: \_\_\_\_\_

